

Name _____ MATH0410119DATE051119

website www.alvarezmathhelp.com

VIDEOS (ON DEMAND MATH0410 119)

(MK ELEMENTARY ALG)

MULTIPLE CHOICE. Choose the one alternative that best completes the statement or answers the question.

Subtract.

- 1) $(-7) - (-20)$ 1) _____
 A) 27 B) -13 C) -27 D) 13

Answer: D

Objective: (1.3) Subtract Real Numbers

ALVAREZLAB GINTEA01...44

POSITIVM (13)

INTERACTMATH SEC 1.3 EXE 14

ALVAREZ VIDEO 1

- 2) $-126.01 - 20.98$ 2) _____
 A) 105.03 B) -146.99 C) 146.99 D) -105.03

Answer: B

Objective: (1.3) Subtract Real Numbers

ALVAREZLAB EXPRABS2 (7) INTERACTMATH SEC 1.3 EXE 37

ALVAREZ VIDEO 2

Simplify using the order of operations.

- 3) $8 + 2(-4 - 1)$ 3) _____
 A) 14 B) 2 C) -2 D) -1

Answer: C

Objective: (1.5) Simplify Using Order of Operations

ALVAREZLAB GINTEA01...44

ORDEROPE (23) INTERACTMATH SEC 1.5 EXE 25

ALVAREZ VIDEO 3

- 4) $\frac{1 + 9(-19 - 3 \cdot 4)}{-3^2 + 11}$ 4) _____
 A) $-\frac{139}{2}$ B) -139 C) $-\frac{197}{2}$ D) -31

Answer: B

Objective: (1.5) Simplify Using Order of Operations

ALVAREZLAB EXPREVAE (23) INTERACTMATH SEC 1.5 EXE 47

ALVAREZ VIDEO 4

Evaluate the following algebraic expression using the indicated values.

5) $-3a^2 - 3b + c - 14$ when $a = 2, b = -3, c = -7$

- A) -24 B) -14 C) -42 D) -18

5) _____

Answer: A

Objective: (1.5) Evaluate Algebraic Expression Using Indicated Values

ALVAREZLAB GINTEA01...44,61...68

EXPREVAE (6) INTERACTMATH SEC 1.5 EXE 55

ALVAREZ VIDEO 5

6) $|6a^2 - b^2| + c$ when $a = -7, b = 3, c = 14$

- A) 59 B) 271 C) 299 D) -299

6) _____

Answer: C

Objective: (1.5) Evaluate Algebraic Expression Using Indicated Values

ALVAREZLAB GINTEA27...31,43...52

EXPRABS1 (22) INTERACTMATH SEC 1.5 EXE 55

ALVAREZ VIDEO 6

Simplify by combining like terms.

7) $7x + 6 + 3x - x + 4$

- A) $10x - 10$ B) $10x + 10$ C) $9x + 10$ D) $11x + 10$

7) _____

Answer: C

Objective: (1.5) Simplify by Combining Like Terms

ALVAREZLAB GFUNSL91...99

EXPRCOMT (5) INTERACTMATH SEC 1.5 EXE 69

ALVAREZ VIDEO 7

Use the Distributive Property to remove parentheses, and then combine like terms.

8) $-4(9r + 7) + 6(3r + 5)$

- A) $-18r + 2$ B) $-18r + 7$ C) $5r + 3$ D) $-64r$

8) _____

Answer: A

Objective: (1.5) Use Distributive Property and Combine Like Terms

ALVAREZLAB GFUNSL91...99 GFOILB69,70,71,72

EXPRCOMT (8,9) INTERACTMATH SEC 1.5 EXE 83

ALVAREZ VIDEO 8

Plot the point on the coordinate plane. State in which quadrant it lies (if any).

9) (2, 1)

9) _____

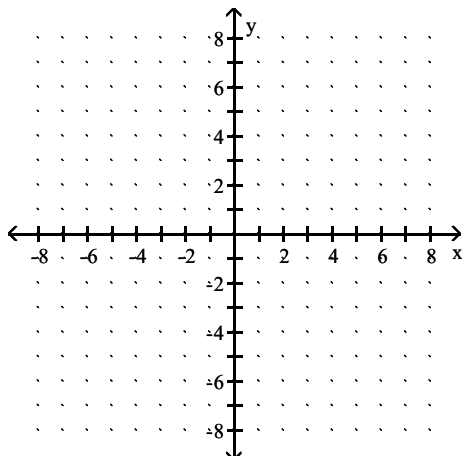

A) quadrant IV

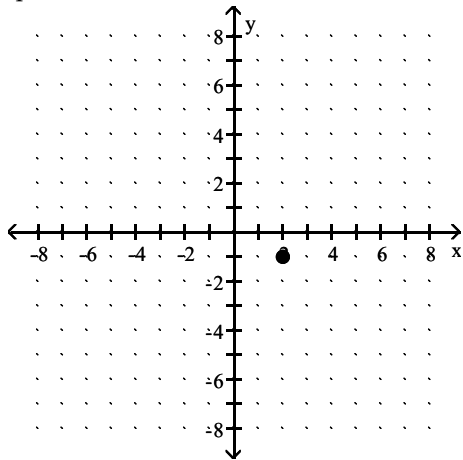

B) quadrant I

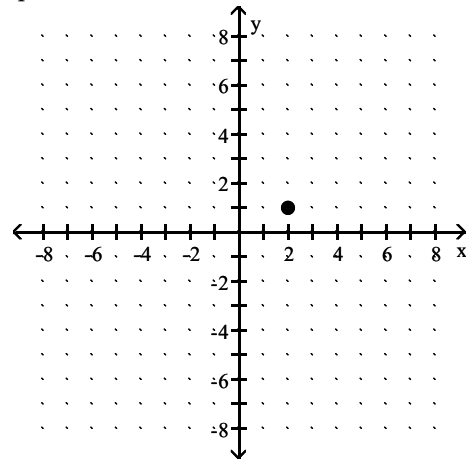

C) quadrant II

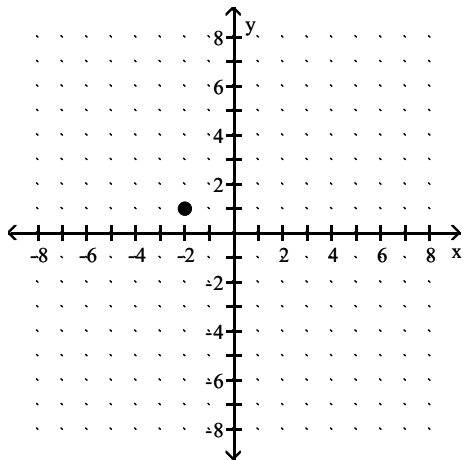

D) quadrant I

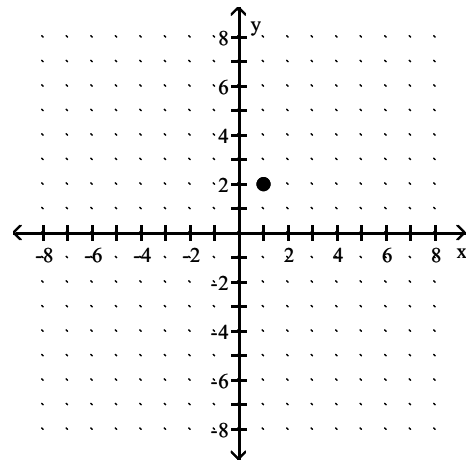

Answer: B

Objective: (1.6) Plot Points on Coordinate Plane

ALVAREZLAB GPOINT01...GPOINT08

INTERACTMATH SEC 1.6 EXE 13

ALVAREZ VIDEO 9

The line graph shows the recorded hourly temperatures in degrees Fahrenheit at an airport. Use the graph to answer the question.

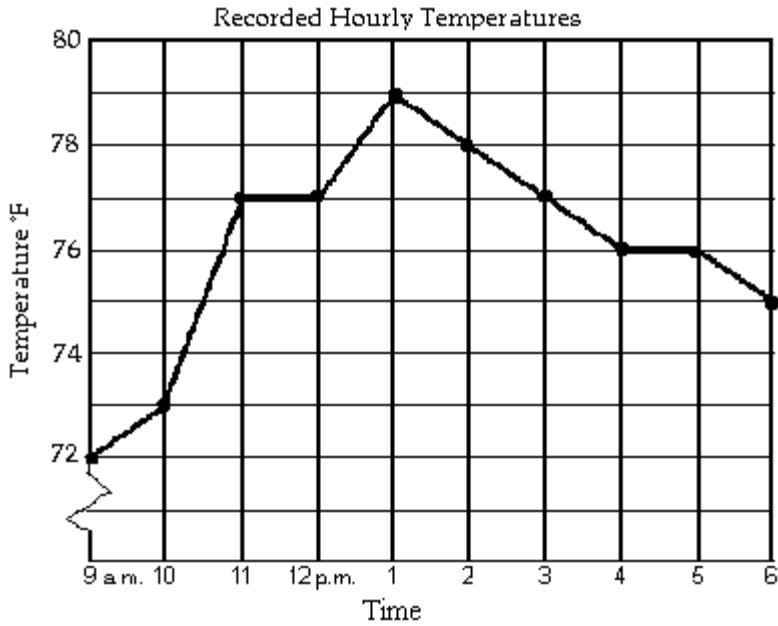

10) At what time was the temperature the highest?

A) 12 p.m.

B) 1 p.m.

C) 2 p.m.

D) 5 p.m.

10) _____

Answer: B

Objective: (1.6) Solve Application Involving Line Graph

ALVAREZLAB GSTOCK01...GSTOCK20

INTERACTMATH SEC 1.6 EXE 49

ALVAREZ VIDEO 10

The bar graph shows the expenditures of one city government in a recent year.

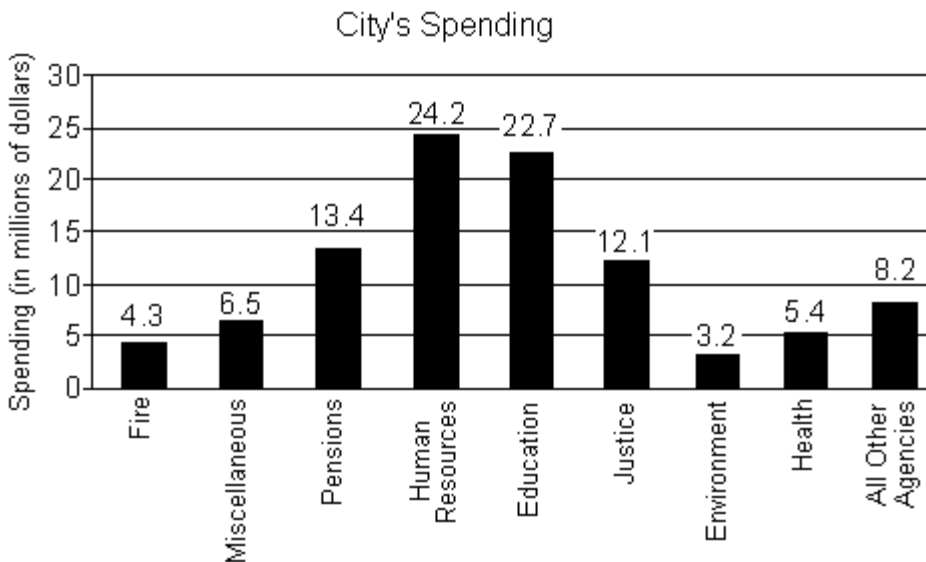

- 11) Name the agency with the largest spending and state this value. 11) _____
- A) Environment; \$3.2 million B) Justice; \$12.1 million
 C) All Other Agencies; \$8.2 million D) Human Resources; \$24.2 million

Answer: D

Objective: (1.7) Solve Application Involving Bar Graph

ALVAREZLAB GSTOCK01 GSTOCK02 INTERACTMAT SEC 1.7 EXE 27

ALVAREZ VIDEO 11

For the problem set up an algebraic equation and solve it.

- 12) The perimeter of a triangle is 50 centimeters. Find the lengths of its sides, if the longest side is 7 centimeters longer than the shortest side, and the remaining side is 4 centimeters longer than the shortest side. 12) _____
- A) The sides are 13 cm, 17 cm, and 24 cm. B) The sides are 6 cm, 9 cm, and 13 cm.
 C) The sides are 17 cm, 21 cm, and 24 cm. D) The sides are 13 cm, 17 cm, and 20 cm.

Answer: D

Objective: (2.1) Solve Application

ALVAREZLAB GLINEQ63..64

LINEQWP1 (1...2...14) LINEQWP2 (1...2...14)

INTERACTMATH SEC 2.1 EXE 91

ALVAREZ--VIDEO 12

Solve the linear equation and check the solution.

- 13) $4(3w + 4) = 2(4w + 24)$ 13) _____
- A) {8} B) {4} C) {16} D) {-4}

Answer: A

Objective: (2.2) Solve Linear Equation (Grouping Symbols)

ALVAREZLAB GLINEQ01...GLINEQ36

LINEQUXX (2) INTERACTMATH SEC 2.2 EXE 21

ALVAREZ--VIDEO 13

14) $-7x + 3(2x - 4) = -9 - 4x$ 14) _____
 A) $\{-7\}$ B) $\{1\}$ C) $\left\{\frac{21}{5}\right\}$ D) $\{-1\}$

Answer: B

Objective: (2.2) Solve Linear Equation (Grouping Symbols)

ALVAREZLAB GLINEQ27...GLINEQ36

LINEQUAT (14) INTERACTMATH SEC 2.2 EXE 23

ALVAREZ--VIDEO 14

15) $4.2p - 19 = 5.2p - 7$ 15) _____
 A) $\{-13\}$ B) $\{-12\}$ C) $\{-7\}$ D) $\{-11\}$

Answer: B

Objective: (2.2) Solve Linear Equation (Decimals)

ALVAREZLAB GLINER01...04

LINEQDEC (10) INTERACTMATH SEC 2.2 EXE 29

ALVAREZ--VIDEO 15

16) $\frac{9}{10}x + \frac{3}{5} = \frac{4}{5}x$ 16) _____
 A) $\{14\}$ B) $\{6\}$ C) $\{-14\}$ D) $\{-6\}$

Answer: D

Objective: (2.2) Solve Linear Equation (Fractions)

ALVAREZLAB GLINEQ41...48, 55...58

LINEQWP1 (12) LINEQWP2 (12) LINEQWOX (12)

INTERACTMATH SEC 2.2 EXE 57

ALVAREZ--VIDEO 16

Determine whether the linear equation is an identity or an inconsistent equation. State the solution set using set notation.

17) $-7x + 8 + 5x = -2x + 13$ 17) _____
 A) $\{5\}$ B) $\{ \}$ or \emptyset C) $\{x \mid x \in \mathcal{R}\}$ D) $\{-8\}$

Answer: B

Objective: (2.2) Identify Inconsistent Equations and Identities

ALVAREZLAB GLINEQ21,25

LINEQUXX (4) INTERACTMATH SEC 2.2 EXE 57

ALVAREZ--VIDEO 17

18) $25x + 3(x + 1) = 28(x + 1) - 25$ 18) _____
 A) $\{1\}$ B) $\{x \mid x \in \mathcal{R}\}$ C) $\{0\}$ D) $\{ \}$ or \emptyset

Answer: B

Objective: (2.2) Identify Inconsistent Equations and Identities

ALVAREZLAB GLINEQ22,26

LINEQUXX (3) INTERACTMATH SEC 2.2 EXE 63

ALVAREZ--VIDEO 18

Solve the problem by utilizing the 4P's: Prepare, Plan, Process, and Ponder.

- 19) A 9-ft. board is cut into 2 pieces so that one piece is 5 feet longer than 3 times the shorter piece. If the shorter piece is x feet long, find the lengths of both pieces. 19) _____
- A) shorter piece: 1 ft; longer piece: 8 ft B) shorter piece: 4.5 ft; longer piece: 27 ft
C) shorter piece: 15 ft; longer piece: 32 ft D) shorter piece: 22 ft; longer piece: 27 ft

Answer: A

Objective: (2.2) Solve 4Ps Application

ALVAREZLAB GLINEQ61...62

LINEQWP1 (1...3..14) LINEQWP2 (1..3..14)

INTERACTMATH SEC 2.2 EXE 97

ALVAREZ--VIDEO 19

Solve for the indicated variable.

- 20) $3x + y = 15$, for y 20) _____
- A) $y = 15 - 3x$ B) $y = 5 - x$ C) $y = 3x + 15$ D) $y = \frac{15 - x}{3}$

Answer: A

Objective: (2.3) Solve Literal Equation for Variable

ALVAREZLAB GLITER01..08

LITERAL (2) INTERACTMATH SEC 2.3 EXE 11

ALVAREZ VIDEO 20

- 21) $15x + 2y = 15$, for y 21) _____
- A) $y = \frac{15}{2}x + \frac{15}{2}$ B) $y = \frac{15}{2}x - \frac{15}{2}$ C) $y = -\frac{15}{2}x + \frac{15}{2}$ D) $y = 15x - 15$

Answer: C

Objective: (2.3) Solve Literal Equation for Variable

ALVAREZLAB GLITER01..08

LITERALE (3) INTERACTMATH SEC 2.3 EXE 25

ALVAREZ--VIDEO 21

- 22) $A = P(1 + rt)$, for t 22) _____
- A) $t = \frac{A - P}{Pr}$ B) $t = \frac{Pr}{A - P}$ C) $t = \frac{A}{r}$ D) $t = \frac{P - A}{Pr}$

Answer: A

Objective: (2.3) Solve Literal Equation for Variable

ALVAREZLAB GLITER15,16

GEOLITE1 (6,7) INTERACTMATH SEC 2.3 EXE 27

ALVAREZ VIDEO 22

- 23) $A = \frac{1}{2}h(a + b)$, for a 23) _____
- A) $a = \frac{2A - hb}{h}$ B) $a = \frac{A - hb}{2h}$ C) $a = \frac{2Ab - h}{h}$ D) $a = \frac{hb - 2A}{h}$

Answer: A

Objective: (2.3) Solve Literal Equation for Variable

ALVAREZLAB GLITER09,10

GEOLITE1 (8,9,10,11) GEOLITE2 (1...18) INTERACTMATH SEC 2.3 EXE 27

ALVAREZ VIDEO 23

24) $S = 2\pi rh + 2\pi r^2$, for h

24) _____

A) $h = \frac{S}{2\pi r} - 1$

B) $h = \frac{S - 2\pi r^2}{2\pi r}$

C) $h = S - r$

D) $h = 2\pi(S - r)$

Answer: B

Objective: (2.3) Solve Literal Equation for Variable

ALVAREZLAB GLITER13,14

GEOLITE1 (19,20) GEOLITE2 (1...18) INTERACTMATH SEC 2.3 EXE 35

ALVAREZ VIDEO 24

Solve the linear inequality and graph the solution set. State the solution using interval notation.

25) $7x > 28$

25) _____

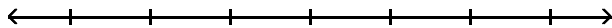

A) $(-\infty, 4]$

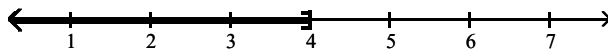

B) $(-\infty, 4)$

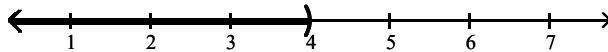

C) $(4, \infty)$

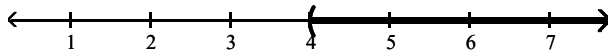

D) $[4, \infty)$

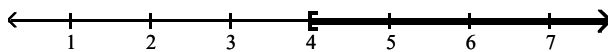

Answer: C

Objective: (2.4) Solve and Graph Linear Inequality

ALVAREZLAB GNUMLY01...20 41...48 51...54

LINEINER (5,6) INTERACTMATH SEC 2.4 EXE 28

ALVAREZ--VIDEO 25

26) $-7x \geq 21$

26) _____

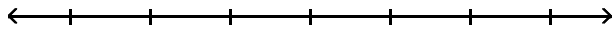

A) $[-3, \infty)$

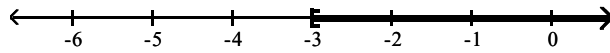

B) $[3, \infty)$

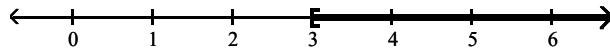

C) $(-\infty, 3]$

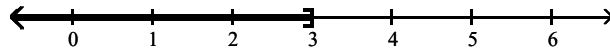

D) $(-\infty, -3]$

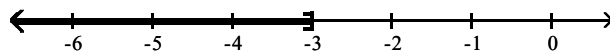

Answer: D

Objective: (2.4) Solve and Graph Linear Inequality

ALVAREZLAB GNUMLY01...20 41...48 51...54

LINEINER (3) INTERACTMATH SEC 2.4 EXE 25

ALVAREZ-- VIDEO 26

27) $36 - 6x \geq -6$

27) _____

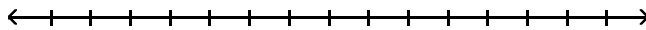

A) $[7, \infty)$

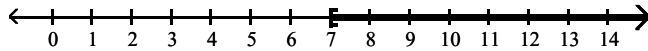

B) $(-\infty, -5]$

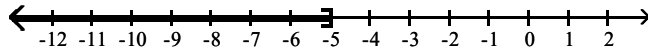

C) $(-\infty, 7]$

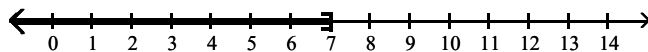

D) $[-5, \infty)$

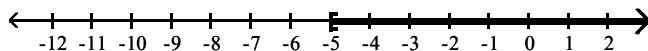

Answer: C

Objective: (2.4) Solve and Graph Linear Inequality

ALVAREZLAB GNUMLY01...20 41...48 51...54

GABSLH01,04,13...16

LINEINER (10) INTERACTMATH SEC 2.4 EXE 43

ALVAREZ-- VIDEO 27

Determine if the ordered pair is a solution to the equation.

28) $(0, 7)$ $10x - 8y = 56$

A) yes

B) no

28) _____

Answer: B

Objective: (3.1) Determine if Ordered Pair Is Solution to Equation
no video

29) $(2, 0)$ $6y + 4x = 8$

A) yes

B) no

29) _____

Answer: A

Objective: (3.1) Determine if Ordered Pair Is Solution to Equation
no video

Graph the solutions to the linear equation by plotting points.

30) $2x + 4y = 8$

30) _____

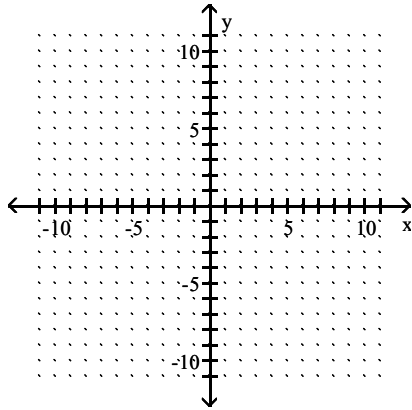

A)

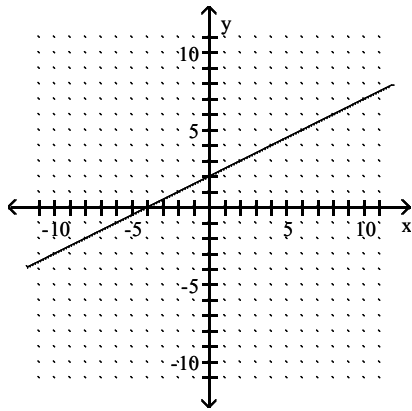

C)

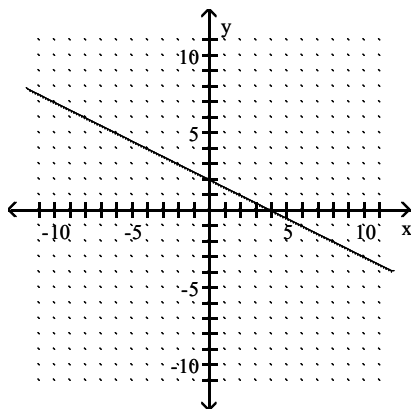

Answer: C

Objective: (3.1) Graph Linear Equation by Plotting Points

B)

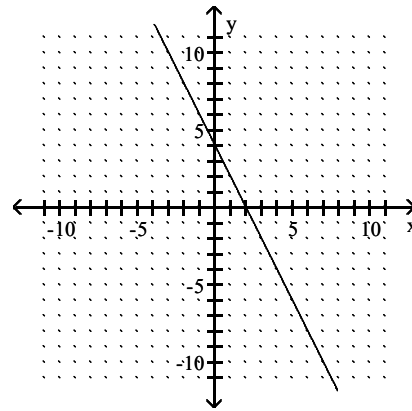

D)

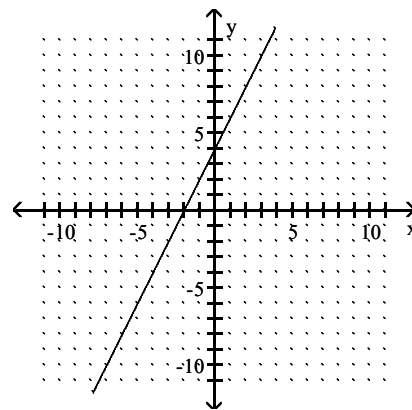

no video

31) $y = 2x - 2$

31) _____

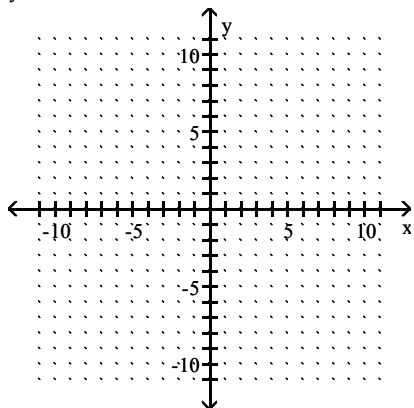

A)

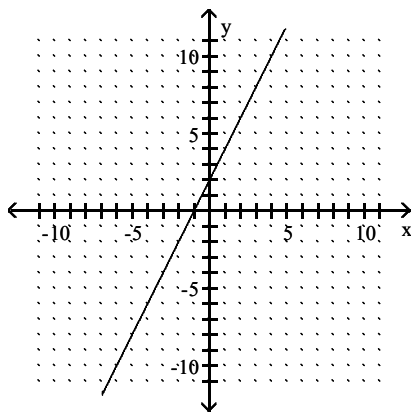

B)

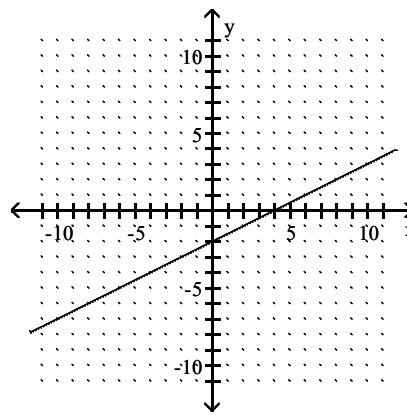

C)

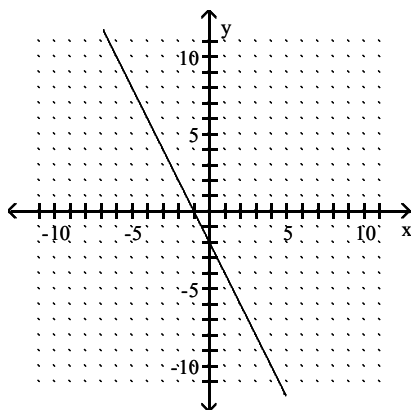

D)

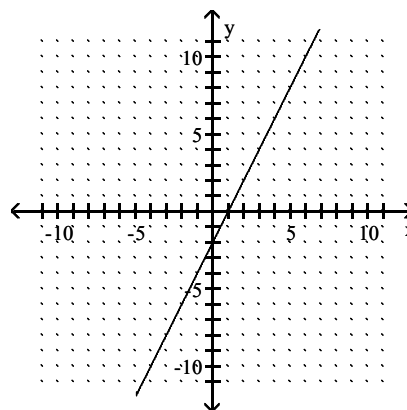

Answer: D

Objective: (3.1) Graph Linear Equation by Plotting Points

ALVAREZLAB BEN1003...BEN1010

INTERACTMATH SEC 3.1 EXE 51

ALVAREZ--VIDEO 28

Find the slope of the straight line through the two solution points.

32) $(8, 3)$ and $(-4, 4)$

32) _____

A) $m = -\frac{1}{12}$

B) $m = -\frac{5}{8}$

C) $m = -\frac{8}{5}$

D) $m = -12$

Answer: A

Objective: (3.3) Find Slope of Line Given Two Points

no video

Find the slope and the y-intercept by using the slope-intercept form of the equation of the line. If necessary, solve for y first.

33) $y = 4x - 5$

33) _____

A) $m = -5, (0, 4)$

B) $m = 4, (0, -5)$

C) $m = 5, (0, 4)$

D) $m = 4, (0, 5)$

Answer: B

Objective: (3.3) Find Slope and y-Intercept Given Equation

no video

34) $2x - 3y = -8$

34) _____

A) $m = \frac{3}{2}, (0, -4)$

B) $m = -\frac{2}{3}, (0, \frac{8}{3})$

C) $m = -\frac{2}{3}, (0, -\frac{8}{3})$

D) $m = \frac{2}{3}, (0, \frac{8}{3})$

Answer: D

Objective: (3.3) Find Slope and y-Intercept Given Equation

no video

Write the equation of the line having the given slope and passing through the given point.

35) $m = 3, (-3, 6)$

35) _____

A) $y = 3x + 15$

B) $x = 3y - 15$

C) $y = 3x - 15$

D) $x = 3y + 15$

Answer: A

Objective: (3.4) Write Equation of Line Given Slope and Point

no video

Determine if the pair of lines is parallel, perpendicular, or neither.

36) $y = 6x - 8$

36) _____

$y = -\frac{1}{6}x - 1$

A) parallel

B) neither

C) perpendicular

Answer: C

Objective: (3.4) Determine if Lines Are Parallel, Perpendicular, or Neither

no video

37) $y = 9x - 6$

37) _____

$y = 9x + 4$

A) neither

B) perpendicular

C) parallel

Answer: C

Objective: (3.4) Determine if Lines Are Parallel, Perpendicular, or Neither

no video

38) $y = 5x - 4$

38) _____

$y = -5x - 8$

A) perpendicular

B) parallel

C) neither

Answer: C

Objective: (3.4) Determine if Lines Are Parallel, Perpendicular, or Neither

no video

39) $3x - 8y = -6$
 $32x + 12y = 8$

A) neither

B) perpendicular

C) parallel

Answer: B

Objective: (3.4) Determine if Lines Are Parallel, Perpendicular, or Neither

no video

39) _____

Graph the linear function. State the domain and range of the function using interval notation.

40) $h(x) = -3x - 5$

40) _____

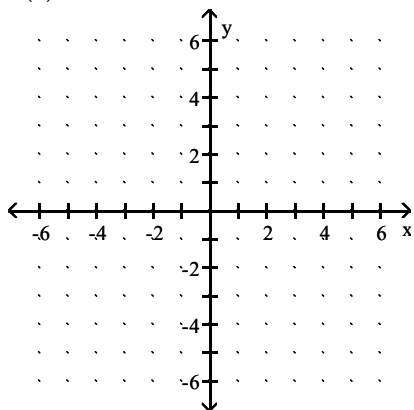

A) $D = (-\infty, \infty)$; $R = (-\infty, \infty)$

B) $D = (-\infty, \infty)$; $R = (-\infty, \infty)$

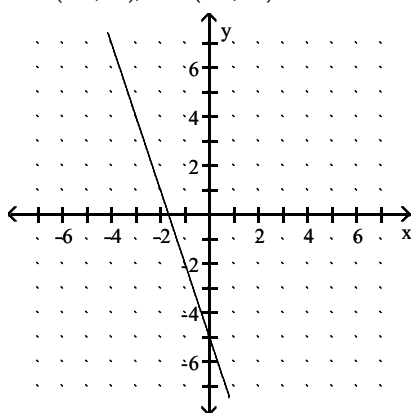

C) $D = (-\infty, \infty)$; $R = (-\infty, \infty)$

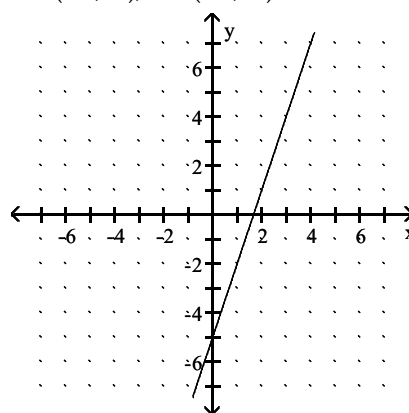

D) $D = (-\infty, \infty)$; $R = (-\infty, \infty)$

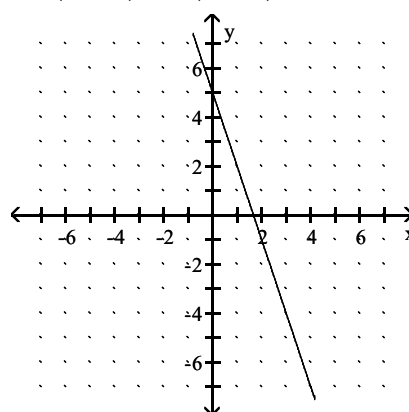
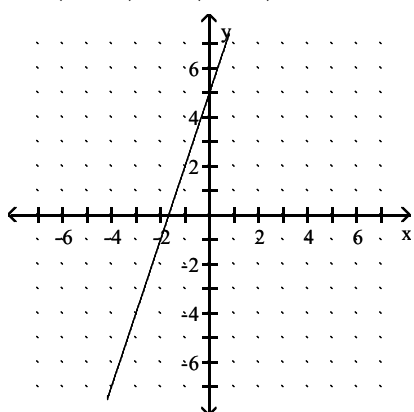

Answer: A

Objective: (3.6) Graph Linear Function and State Domain and Range

ALVAREZLAB BEN1003..BEN1010

INTERACTMATH SEC 3.6 EXE 29

ALVAREZ VIDEO 29

41) $f(x) = \frac{1}{2}x + 3$

41) _____

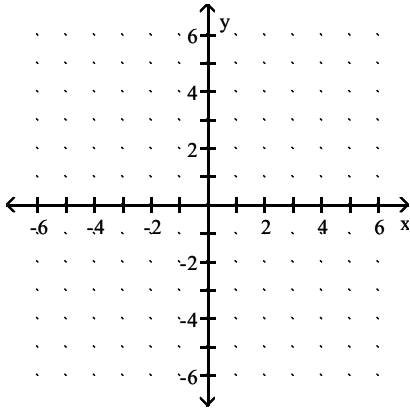

A) $D = (-\infty, \infty); R = (-\infty, \infty)$

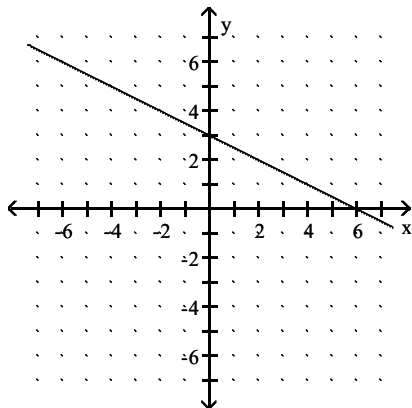

C) $D = (-\infty, \infty); R = (-\infty, \infty)$

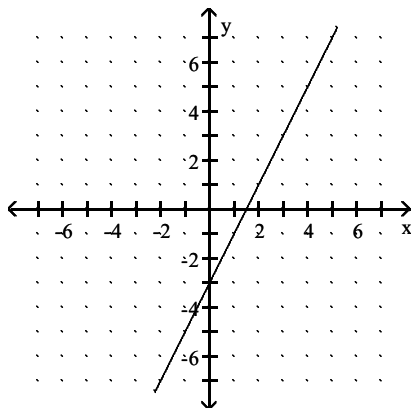

B) $D = (-\infty, \infty); R = (-\infty, \infty)$

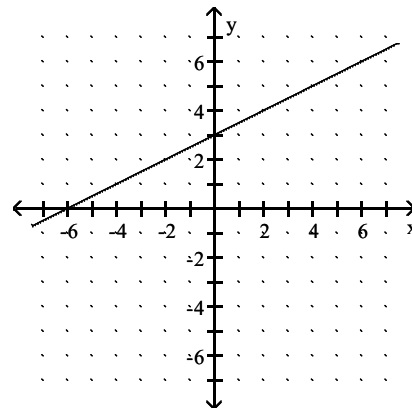

D) $D = (-\infty, \infty); R = (-\infty, \infty)$

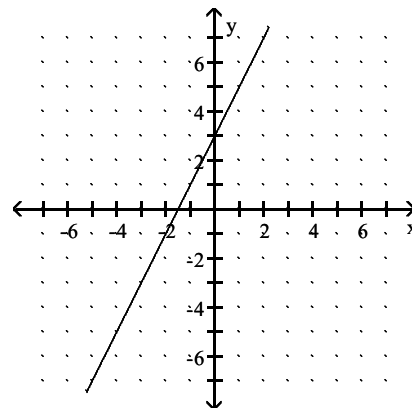

Answer: B

Objective: (3.6) Graph Linear Function and State Domain and Range

ALVAREZLAB BEN1014...BEN1021

INTERACTMATH SEC 3.6 EXE 34

ALVAREZ--VIDEO 30

Evaluate the function at the given value of the independent variable. State the answer as an ordered pair.

42) $g(x) = 8x + 3$, $g(a)$ 42) _____
A) $(a, 8a + 3)$ B) $(a, 24a)$ C) $(a, 11a)$ D) $(a, 11)$

Answer: A

Objective: (3.6) Evaluate Function

ALVAREZLAB FUNCTVA1 (1...14)

INTERACTMATH SEC 3.6 EXE 41

ALVAREZ VIDEO 31

43) $f(x) = 5x^2 + 4x + 2$; $f(-4)$ 43) _____
A) $(-4, 2)$ B) $(-4, 62)$ C) $(-4, 66)$ D) $(-4, 98)$

Answer: C

Objective: (3.6) Evaluate Function

ALVAREZLAB GFUNEV01...06

FUNCTP01 (1...14) FUNCTP02 (1...16)

INTERACTMATH SEC 3.6 EXE 46

ALVAREZ-- VIDEO 32

44) $f(x) = |x - 7|$; $f(-9)$ 44) _____
A) $(-9, -9)$ B) $(-9, 7)$ C) $(-9, 16)$ D) $(-9, -16)$

Answer: C

Objective: (3.6) Evaluate Function

ALVAREZLAB GFUNEV09,10

FUNCTP02 (16) INTERACTMATH SEC 3.6 EXE 49

ALVAREZ-- VIDEO 33

45) $h(x) = \frac{x^2 - 4}{x}$; $h(-4)$ 45) _____
A) $(-3, -4)$ B) $(-4, -5)$ C) $(-4, -3)$ D) $(-4, 3)$

Answer: C

Objective: (3.6) Evaluate Function

ALVAREZLAB GFUNEV12

FUNCTP02 (13,14) INTERACTMATH (6) INTERACTMATH SEC 3.6 EXE 46

ALVAREZ-- VIDEO 34

Solve the system of linear equations using the method of your choice.

46) $\begin{cases} 2x + y = 5 \\ 4x + 3y = 7 \end{cases}$ 46) _____
A) $\{(-4, 13)\}$ B) $\{(4, -3)\}$
C) $\{ \}$ D) $\{(x, y) \mid 2x + y = 5\}$

Answer: B

Objective: (4.5) Solve System of Linear Equations Using Any Method

no video

47) $\begin{cases} -x + 3y = 11 \\ 3x + 4y = 6 \end{cases}$ 47) _____
A) $\{(-2, 3)\}$ B) $\{ \}$
C) $\{(x, y) \mid -x + 3y = 11\}$ D) $\{(13, 2)\}$

Answer: A

Objective: (4.5) Solve System of Linear Equations Using Any Method

no video

48) $\begin{cases} 3x + 5y = 19 \\ 6x + 10y = 29 \end{cases}$ 48) _____
 A) $\{(3, -4)\}$ B) $\{ \}$
 C) $\{(x, y) \mid 3x + 5y = 19\}$ D) $\{(3, 2)\}$

Answer: B

Objective: (4.5) Solve System of Linear Equations Using Any Method

49) $\begin{cases} 3x + 2y = 13 \\ -6x - 4y = -26 \end{cases}$ 49) _____
 A) $\{ \}$ B) $\{(x, y) \mid 3x + 2y = 13\}$
 C) $\{(3, -4)\}$ D) $\{(3, 2)\}$

Answer: B

Objective: (4.5) Solve System of Linear Equations Using Any Method

no video

Set up a system of two equations and solve by any method.

50) Find two integers whose sum is -10 and whose difference is 6. 50) _____
 A) - 2 and - 8 B) -10 and 2 C) - 5 and - 11 D) - 4 and - 6

Answer: A

Objective: (4.5) Solve Application

no video

51) Find two numbers such that the first is four more than the second and two times the first is 2 more than four times the second. 51) _____
 A) - 5 and - 9 B) 7 and 3 C) 8 and 4 D) 6 and 2

Answer: B

Objective: (4.5) Solve Application

no video

52) Raleigh has 63 dimes and nickels. The total value of the coins is \$5.20. Find the number of each type of coin. 52) _____
 A) 41 nickels and 22 dimes B) 24 nickels and 39 dimes
 C) 22 nickels and 41 dimes D) 27 nickels and 36 dimes

Answer: C

Objective: (4.5) Solve Application

no video

Simplify the expression using the product-to-a-power rule. Write the answer in lowest terms with positive powers only. Assume that all variables represent nonzero real numbers.

53) $(4x^8y^{-6}z)^{-2}$ 53) _____
 A) $\frac{1}{16x^{16}y^{12}z^2}$ B) $\frac{y^{12}}{16x^{16}z^2}$ C) $\frac{-8y^{12}}{x^{16}z^2}$ D) $4x^8y^{12}z^2$

Answer: B

Objective: (5.1) Simplify Using Product-to-Power Rule

ALVAREZLAB POWERS (11,12) INTERACTMATH SEC 5.1 EXE 65

ALVAREZ--VIDEO 35

Simplify the expression using the quotient-to-a-power rule. Write the answer in lowest terms with positive powers only. Assume that all variables represent nonzero real numbers.

54) $\left(\frac{5x^4y^5}{7z^{10}}\right)^2$ 54) _____

A) $\frac{25x^8y^{10}}{7z^{12}}$ B) $\frac{25x^6y^7}{49z^{12}}$ C) $\frac{25x^8y^7}{49z^{20}}$ D) $\frac{25x^8y^{10}}{49z^{20}}$

Answer: D

Objective: (5.1) Simplify Using Quotient-to-Power Rule

ALVAREZLAB POWERS (10) INTERACTMATH SEC 5.1 EXE 47

ALVAREZ--VIDEO 36

55) $\left(\frac{2x^3y^{-3}}{x^{-5}y^3}\right)^{-2}$ 55) _____

A) $\frac{y^{12}}{2x^{16}}$ B) $\frac{2x^{16}}{y^{12}}$ C) $\frac{y^{12}}{4x^{16}}$ D) $\frac{y^{12}}{2x^8}$

Answer: C

Objective: (5.1) Simplify Using Quotient-to-Power Rule

no video

Add. Write the sum in descending powers of the variable.

56) $(10z - 10) + (z^2 - z + 2)$ 56) _____

A) $10z - 12$ B) $z^2 + 9z - 8$ C) $z^2 + 9z - 12$ D) $10z - 8$

Answer: B

Objective: (5.3) Add Polynomials

ALVAREZLAB GFUNSL01,05

POLYSIMP (1) INTERACTMATH SEC 5.3 EXE 21

ALVAREZ VIDEO 37

Subtract. Write the difference in descending powers of the variable.

57) $(8x^2 - 5x + 20) - (3x^2 + 5x - 40)$ 57) _____

A) $5x^2 + 10x + 60$ B) $5x^2 + 10x - 60$ C) $5x^2 - 10x - 20$ D) $5x^2 - 10x + 60$

Answer: D

Objective: (5.3) Subtract Polynomials

ALVAREZLAB GFUNSL02,06

POLYSIMP (2) INTERACTMATH SEC 5.3 EXE 32

ALVAREZ-VIDEO 38

Perform the indicated operations. Write the answer in descending powers of the variable.

58) $(6x^4 - 5x^2 + x) - (9x^3 + 4x^2 + 8x) + (3x^2 - x)$ 58) _____

A) $6x^4 - 9x^3 - 4x^2 + 8x$ B) $6x^4 + 9x^3 - 12x^2 - 8x$
 C) $6x^4 - 9x^3 - 6x^2 - 8x$ D) $-3x^5 + 7x^4 - 8x$

Answer: C

Objective: (5.3) Add/Subtract Three Polynomials

ALVAREZLAB GFUNSL01,02,05,06

POLYSIMP (4) INTERACTMATH SEC 5.3 EXE 32

ALVAREZ VIDEO 39

Evaluate the polynomial with the indicated value for the variable.

- 59) $-2x^3 - 5x^2 - x - 46$ for $x = -2$ 59) _____
A) -58 B) -60 C) -18 D) -48

Answer: D

Objective: (5.3) Evaluate Polynomial

ALVAREZLAB EXPREVAE (17,18,19,20) INTERACTMATH SEC 5.3 EXE 49

ALVAREZ VIDEO 40

- 60) Given the polynomial function $P(x) = -4x^2 + 5x + 2$, find $P(2)$. 60) _____
A) -14 B) -4 C) -8 D) 4

Answer: B

Objective: (5.3) Evaluate Polynomial

ALVAREZLAB GFUNEV01...06

FUNCTE04 (4,5,6,7) INTERACTMATH SEC 5.3 EXE 51

ALVAREZ-- VIDEO 41

Multiply using the Distributive Property.

- 61) $(z + 4)(z + 9)$ 61) _____
A) $2z + 36$ B) $2z^2 + 36$ C) $z^2 + 13z + 13$ D) $z^2 + 13z + 36$

Answer: D

Objective: (5.4) Multiply Binomial by Binomial

ALVAREZLAB GFOILB05...18

POLYSIMP (7,8) INTERACTMATH SEC 5.4 EXE 31

ALVAREZ-- VIDEO 42

Multiply.

- 62) $(x + 1)(x^2 - x + 1)$ 62) _____
A) $x^3 + 2x^2 + 2x + 1$ B) $x^3 - 2x^2 - 2x - 1$
C) $x^3 - 1$ D) $x^3 + 1$

Answer: D

Objective: (5.4) Multiply Polynomial by Polynomial

ALVAREZLAB GFOILB33...40

POLYSIMP (13..16) INTERACTMATH SEC 5.4 EXE 55

ALVAREZ-- VIDEO 43

Square using special products.

- 63) $(7b + 3)^2$ 63) _____
A) $7b^2 + 42b + 9$ B) $49b^2 + 42b + 9$
C) $7b^2 + 9$ D) $49b^2 + 9$

Answer: B

Objective: (5.5) Square Binomial

ALVAREZLAB GFOILB21,22,31,32

POLYSIMP (19) INTERACTMATH SEC 5.5 EXE 27

ALVAREZ-- VIDEO 44

64) $(4x - 11y)^2$

A) $4x^2 + 121y^2$

C) $16x^2 - 88xy + 121y^2$

B) $16x^2 + 121y^2$

D) $4x^2 - 88xy + 121y^2$

64) _____

Answer: C

Objective: (5.5) Square Binomial

ALVAREZLAB GFOILB21,22,31,32

POLYSIMQ (15,16) INTERACTMATH SEC 5.5 EXE 31

ALVAREZ--VIDEO 45

Use the special product of a sum and difference of two terms to multiply the binomials.

65) $(10a + 3b)(10a - 3b)$

A) $100a^2 - 60ab - 9b^2$

C) $10a^2 - 3b^2$

B) $100a^2 + 60ab - 9b^2$

D) $100a^2 - 9b^2$

65) _____

Answer: D

Objective: (5.5) Multiply Sum and Difference of Two Terms

ALVAREZLAB GFOILB18,19,27,28

POLYSIMQ (15,16) INTERACTMATH SEC 5.5 EXE 51

ALVAREZ--VIDEO 46

Divide. Write answer in lowest terms using positive powers only.

66) $\frac{19x^7y^7z^3}{76x^5y^9}$

A) $\frac{4x^2}{y^2z^3}$

B) $\frac{4x^2z^3}{y^2}$

C) $\frac{x^2}{4y^2}$

D) $\frac{x^2z^3}{4y^2}$

66) _____

Answer: D

Objective: (5.6) Divide Using Exponent Rules

ALVAREZLAB GFACTR75,76

POWERS (7,8,9,10) INTERACTMATH SEC 5.6 EXE 9

ALVAREZ--VIDEO 47Divide using long division. Write answer as Quotient + $\frac{\text{Remainder}}{\text{Divisor}}$.

67) $(6x^2 - 25x - 13) \div (x - 5)$

A) $6x + 5$

B) $6x - 5 + \frac{12}{x - 5}$

C) $6x + 5 + \frac{12}{x - 5}$

D) $6x + 5 - \frac{12}{x - 5}$

67) _____

Answer: C

Objective: (5.6) Divide Using Long Division (Remainder)

ALVAREZLAB GSYNTK01...10

DIVISION (5) INTERACTMATH SEC 5.6 EXE 25

ALVAREZ--VIDEO 48

Factor out the GCF using the Distributive Property.

68) $m^3n^2 - m^2n^4$ 68) _____
A) $m^2n^2(m - n^2)$ B) $mn(6 - 8)$ C) $m^3n^4(m - n^2)$ D) $m^3n^2(1 - mn^2)$

Answer: A

Objective: (6.1) Factor Out GCF

ALVAREZLAB GFACTR57...64

POLYFACM (8) INTERACTMATH SEC 5.6 EXE 9

ALVAREZ--VIDEO 49

69) $5x(3x + 4) - 4(3x + 4)$ 69) _____
A) $(5x - 4)(3x + 4)$ B) $(15x + 4)(x - 4)$ C) $(5x + 4)(3x - 4)$ D) $(15x - 4)(x + 4)$

Answer: A

Objective: (6.1) Factor Out GCF (Binomial Factor)

ALVAREZLAB GFACTR05...16 81...84

FACTGROU (1) INTERACTMAT SEC 6.1 EXE 63

ALVAREZ VIDEO 50

70) $t(2 - m) + s(2 - m)$ 70) _____
A) $t(2 - m) + s$ B) $2 - m$ C) $(t - s)(2 - m)$ D) $(t + s)(2 - m)$

Answer: D

Objective: (6.1) Factor Out GCF (Binomial Factor)

ALVAREZLAB GFACTR05...16 81...84

FACTGROU (3) INTERACTMATH SEC 6.1 EXE 65

ALVAREZ VIDEO 51

Factor by grouping.

71) $x^2 + 4x + xy + 4y$ 71) _____
A) $(x - 4)(x - y)$ B) $(x + 4)(x - y)$ C) $(x - 4)(x + y)$ D) $(x + 4)(x + y)$

Answer: D

Objective: (6.1) Factor by Grouping

ALVAREZLAB GFACTR17...20

QUADGROU (7) INTERACTMATH SEC 6.1 EXE 69

ALVAREZ VIDEO 52

72) $r^2 - 8r + rt - 8t$ 72) _____
A) $(r - 8)(r + t)$ B) $(r + 8)(r - t)$ C) $(r - 8)(r - t)$ D) $rt(r - 8)$

Answer: A

Objective: (6.1) Factor by Grouping

ALVAREZLAB GFACTR17...20

QUADGROU (7) INTERACTMATH SEC 6.1 EXE 69

ALVAREZ--VIDEO 53

Factor, if possible, using the difference or sum of squares. If a polynomial is not factorable, write "prime."

73) $36k^2 - 169m^2$ 73) _____
A) prime B) $(6k + 13m)^2$
C) $(6k + 13m)(6k - 13m)$ D) $(6k - 13m)^2$

Answer: C

Objective: (6.2) Factor Sum or Difference of Squares

ALVAREZLAB GFACTR21...24,91,92,93,94

FACTORIN (5,6) INTERACTMATH SEC 6.2 EXE 25

ALVAREZ VIDEO 54

Factor using the sum or difference of cubes.

74) $64x^3 - 27$

A) $(4x - 3)(16x^2 + 9)$

B) $(4x - 3)(16x^2 + 12x + 9)$

C) $(64x - 3)(x^2 + 12x + 9)$

D) $(4x + 3)(16x^2 - 12x + 9)$

Answer: B

Objective: (6.2) Factor Sum or Difference of Cubes

ALVAREZLAB GFACTR30,32,34,36

FACTORIN (17,19,21,23) INTERACTMATH SEC 6.2 EXE 35

ALVAREZ--VIDEO 55

75) $27a^3 + 64b^3$

A) $(3a - 4b)(9a^2 + 12ab + 16b^2)$

B) $(3a + 4b)(9a^2 + 16b^2)$

C) $(3a + 4b)(9a^2 - 12ab + 16b^2)$

D) $(27a + 4b)(a^2 - 12ab + 16b^2)$

Answer: C

Objective: (6.2) Factor Sum or Difference of Cubes

ALVAREZLAB GFACTR29,31,33,35

FACTORIN (22) INTERACTMATH SEC 6.2 EXE 37

ALVAREZ--VIDEO 56

Using the general factoring strategy, factor completely. If a polynomial is not factorable, write "prime."

76) $3x^2 - 27$

A) $3(x - 3)^2$

B) $3(x + 3)(x - 3)$

C) $(3x + 9)(x - 3)$

D) $(3x + 3)(x - 9)$

Answer: B

Objective: (6.2) Factor Using General Strategy

ALVAREZLAB GFACTR25...26

FACTORI1 (5,6,7) INTERACTMATH SEC 6.2 EXE 47

ALVAREZ--VIDEO 57

Factor the trinomial using the AC Method. If a trinomial is not factorable, write "prime."

77) $4x^2 + 12x + 9$

A) prime

B) $(2x - 3)(2x - 3)$

C) $(4x + 3)(x + 3)$

D) $(2x + 3)(2x + 3)$

Answer: D

Objective: (6.3) Factor Using AC Method

ALVAERZLAB GFACTR43...50

FACTORIN (10) INTERACTMATH SEC 6.3 EXE 11

ALVAERZ--VIDEO 58

78) $15z^2 - 14z - 8$

A) $(3z - 4)(5z + 2)$

B) prime

C) $(15z - 4)(z + 2)$

D) $(3z + 4)(5z - 2)$

Answer: A

Objective: (6.3) Factor Using AC Method

ALVAREZLAB GFACTR43...50

FACTORIN (11) INTERACTMATH SEC 6.3 EXE 15

ALVAREZ--VIDEO 59

74) _____

75) _____

76) _____

77) _____

78) _____

Factor the trinomial using the Educated Guess-and-Test Method. If a trinomial is not factorable, write "prime."

79) $2x^2 - 19x + 35$ 79) _____
A) $(5 - 2x)(2x - 5)$ B) $(2x + 30)(2x - 5)$ C) $(x + 7)(2x - 5)$ D) $(x - 7)(2x - 5)$

Answer: D

Objective: (6.3) Factor Using Educated Guess-and-Test Method

ALVAREZLAB GFACTR43...50

FACTORIN (12) INTERACTMATH SEC 6.3 EXE 17

ALVAREZ--VIDEO 60

Factor the trinomial completely using the general factoring strategy. If a trinomial is not factorable, write "prime."

80) $27x^2 - 117x - 90$ 80) _____
A) $(3x + 2)(9x - 45)$ B) $9(3x + 2)(x - 5)$ C) $(27x + 18)(x - 5)$ D) $9(3x - 2)(x + 5)$

Answer: B

Objective: (6.3) Factor Using General Strategy

ALVAREZLAB GFACTR51...54

FACTORIN (4) FACTORI1 (12,13,14,15,16) INTERACTMATH SEC 6.3 EXE 80

ALVAREZ--VIDEO 61

Factor the trinomial using the general factoring strategy. If a trinomial is not factorable, write "prime."

81) $4x^2 - 4x - 24$ 81) _____
A) prime B) $4(x - 2)(x + 3)$ C) $4(x + 2)(x - 3)$ D) $(4x + 8)(x - 3)$

Answer: C

Objective: (6.4) Factor Using General Strategy

ALVAREZLAB GFACTR51...54

FACTORI1 (1,2,3,4,12,13,14,15,16) INTERACTMATH SEC 6.4 EXE 71

ALVAREZ--VIDEO 62

82) $2x^3 + 2x^2 - 12x$ 82) _____
A) $2x(x - 2)(x + 3)$ B) prime C) $(2x^2 + 4x)(x - 3)$ D) $2x(x + 2)(x - 3)$

Answer: A

Objective: (6.4) Factor Using General Strategy

ALVAREZLAB GFACTR55...56

FACTORI1 (8,9,10,11) INTERACTMATH SEC 6.4 EXE 93

ALVAREZ--VIDEO 63

Factor the polynomial completely using the general factoring strategy. If the polynomial is not factorable, write "prime."

83) $3(x - 2) - a(x - 2)$ 83) _____
A) $3a(x - 2)$ B) $(3 - a)(x - 2)$ C) $(3x - 2)(x - a)$ D) $(3x + 2)(x - a)$

Answer: B

Objective: (6.5) Factor Out Common Factor

ALVAREZLAB GFACTR05...16

FACTGROU (1,2,3,4,17,18,19,20) INTERACTMATH SEC 6.5 EXE 65

ALVAREZ VIDEO 64

84) $18s^7t^3 + 6s^5t^4$ 84) _____
 A) $6s^2t(3s + t)$ B) $s^5t^3(18s + 6t)$ C) $6s^5t^3(3s^2 + t)$ D) $6s^7t^4(3s^2 + t)$

Answer: C

Objective: (6.5) Factor Out Common Factor

ALVAREZLAB GFACTR69,57...64

FACTORIN (3) FACTORI1 (8,9,10,11) INTERACTMATH SEC 6.5 EXE 51

ALVAREZ--VIDEO 65

85) $9x^5y^2 - 25x^3y^2$ 85) _____
 A) $x^3y^2(3x + 5)(3x + 5)$ B) prime
 C) $x^3y^2(3x + 5)(3x - 5)$ D) $(3x + 5)(3x - 5)$

Answer: C

Objective: (6.5) Factor Binomial

ALVAREZLAB GFACTR65...69

FACTORIN (3) FACTORI1 (5,6,8,9,10,11) INTERACTMATH SEC 6.5 EXE 51

ALVAREZ VIDEO 66

86) $16m^3 - 250$ 86) _____
 A) $2(2m - 5)(4m^2 + 10m + 25)$ B) $2(8m - 5)(m^2 + 10m + 25)$
 C) $2(2m + 5)(4m^2 - 10m + 25m)$ D) $(4m - 10)(4m^2 + 25)$

Answer: A

Objective: (6.5) Factor Binomial

ALVAREZLAB GFACTR35...36

FACTORIN (23,24) INTERACTMATH 6.5 EXE 45

ALVAREZ VIDEO 67

87) $x^2 - 7x - 18$ 87) _____
 A) prime B) $(x - 18)(x + 1)$ C) $(x - 2)(x + 9)$ D) $(x + 2)(x - 9)$

Answer: D

Objective: (6.5) Factor Trinomial

ALVAREZLAB GFACTR37...42

FACTORIN (2) INTERACTMATH SEC 6.5 EXE 31

ALVAREZ--VIDEO 68

88) $2x^2 + 4x - 30$ 88) _____
 A) $2x(x + 3y)(x - 5y)$ B) $(2x + 6x)(x - 5)$
 C) $2(x - 3)(x + 5)$ D) prime

Answer: C

Objective: (6.5) Factor Trinomial

ALVAREZLAB GFACTR51...54

FACTORIN (4) FACTORI1 (1,2,3,4) INTERACTMATH SEC 6.5 EXE 65

ALVAREZ--VIDEO 69

89) $ya - 8a + 7y - 56$
 A) $(y + 8)(a - 7)$ B) $(y - 8a)(y + 7)$ C) $(y - 7)(a + 8)$ D) $(y - 8)(a + 7)$

89) _____

Answer: D

Objective: (6.5) Factor Polynomial with More Than Three Terms

ALVAREZLAB GFACTR17...20

FACTGROU (17,18,19,20) FACTORI1 (17,18,19,20,21,22)

INTERACTMATH SEC 6.5 EXE 65

ALVAREZ VIDEO 70

Solve the equation using the Zero Factor Property and state the solution set.

90) $(x - 3)(x + 2) = 0$
 A) $\{3, 2\}$ B) $\{3, -2\}$ C) $\{-3, 2\}$ D) $\{3, -3, 2, -2\}$

90) _____

Answer: B

Objective: (6.6) Solve Equation Using Zero Factor Property (Equation = 0)

ALVAREZLAB GQUADM01...10

QUADFAE1 (1,2) INTERACTMATH SEC 6.6 EXE 13

ALVAREZ--VIDEO 71

91) $(2y + 15)(5y + 6) = 0$
 A) $\left\{-\frac{15}{2}, -\frac{6}{5}\right\}$ B) $\left\{-\frac{2}{13}, -\frac{5}{6}\right\}$ C) $\{13, 1\}$ D) $\left\{\frac{15}{2}, \frac{6}{5}\right\}$

91) _____

Answer: A

Objective: (6.6) Solve Equation Using Zero Factor Property (Equation = 0)

ALVAREZLAB GQUADF01..10 GQUADM01...10

QUADFAE1 (1,2) INTERACTMATH SEC 6.6 EXE 15

ALVAREZ--VIDEO 72

92) $5b(b + 13) = 0$
 A) $\{-5, -13\}$ B) $\{-13, 0\}$ C) $\{5, -13\}$ D) $\{13, 0\}$

92) _____

Answer: B

Objective: (6.6) Solve Equation Using Zero Factor Property (Equation = 0)

ALVAREZLAB GQUADM11...18 GQUADF07...10

QUADFAE1 (12...18) QUADFACT (15...30) QUADFACX (1...8)

INTERACTMATH SEC 6.6 EXE 11

ALVAREZ--VIDEO 73

93) $42n^2 + 91n = 0$
 A) $\left\{-\frac{13}{6}, 91\right\}$ B) $\left\{-\frac{13}{6}, 0\right\}$ C) $\{0\}$ D) $\left\{-\frac{13}{6}\right\}$

93) _____

Answer: B

Objective: (6.6) Solve Equation Using Zero Factor Property (Equation = 0)

ALVAREZLAB GQUADN11...18 GQUADF15..18

QUADFACT (24) INTERACTMATH SEC 6.6 EXE 23

ALVAREZ--VIDEO 74

- 94) $x^2 - 10x + 25 = 0$ 94) _____
 A) {0, 5} B) {-5} C) {5} D) {-5, 5}
- Answer: C
Objective: (6.6) Solve Equation Using Zero Factor Property (Equation = 0)
 ALVAREZLAB GQUADN01...09
 QUADFACT (7) INTERACTMATH SEC 6.6 EXE 37
ALVAREZ--VIDEO 75
- 95) $y^2 - 121 = 0$ 95) _____
 A) {0, 11} B) {11} C) {-11, 11} D) {-11}
- Answer: C
Objective: (6.6) Solve Equation Using Zero Factor Property (Equation = 0)
 ALVAREZLAB GQUADN10
 QUADFACX (1,5) INTERACTMATH SEC 6.6 EXE 19
ALVAREZ--VIDEO 76
- 96) $x^2 - x = 20$ 96) _____
 A) {1, 20} B) {-4, 5} C) {4, 5} D) {-4, -5}
- Answer: B
Objective: (6.6) Solve Equation Using Zero Factor Property (Equation \neq 0)
 ALVAREZLAB GQUADN21...29
 QUADFACT (1,2,...10) INTERACTMATH SEC 6.6 EXE 31
ALVAREZ--VIDEO 77
- 97) $6b^2 + 25b + 5 = -20$ 97) _____
 A) $\left\{-\frac{5}{2}, -\frac{5}{3}\right\}$ B) $\left\{\frac{2}{5}, \frac{3}{5}\right\}$ C) $\left\{\frac{5}{2}, \frac{5}{3}\right\}$ D) $\left\{-\frac{2}{5}, -\frac{5}{3}\right\}$
- Answer: A
Objective: (6.6) Solve Equation Using Zero Factor Property (Equation \neq 0)
 ALVAREZLAB GQUADF11..22 GQUADN01...58
 QUADFACX (8) INTERACTMATH SEC 6.6 EXE 39
ALVAREZ--VIDEO 78
- 98) $x(x - 8) = 20$ 98) _____
 A) {2, -10} B) {-2, -10} C) {-2, 10} D) {2, 10}
- Answer: C
Objective: (6.6) Solve Equation Using Zero Factor Property (Equation \neq 0)
 ALVAREZLAB GQUADN50...GQUADN55
 QUADFACT (8) INTERACTMATH SEC 6.6 EXE 43
ALVAREZ--VIDEO 79
- 99) $x^2 = 256$ 99) _____
 A) {16} B) {-16, 16} C) {0, -16} D) {-16}
- Answer: B
Objective: (6.6) Solve Equation Using Zero Factor Property (Equation \neq 0)
 ALVAREZLAB GQUADN30 GQUADF17..18
 QUADFACX (2) INTERACTMATH SEC 6.6 EXE 21
ALVAREZ--VIDEO 80

100) $t^2 + 4 = -4t$ 100) _____
 A) $\{-2\}$ B) $\{-2, 2\}$ C) $\{0, -2\}$ D) $\{2\}$

Answer: A

Objective: (6.6) Solve Equation Using Zero Factor Property (Equation $\neq 0$)

ALVAREZLAB GQUADN21...29 GQUADN56...65

QUADFACT(2,10) INTERACTMATH SEC 6.6 EXE 31

ALVAREZ--VIDEO 81

Evaluate the polynomial function for the indicated value.

101) $P(x) = x^2 - 2x + 4$ 101) _____
 A) -1 B) -5 C) 7 D) 3

Answer: D

Objective: (6.6) Evaluate Polynomial Function

ALVAREZLAB GFUNEV01...GFUNEV04

FUNCTE04 (3,4) INTERACTMATH SEC 6.6 EXE 47

ALVAREZ--VIDEO 82

102) $P(x) = -5x^2 + 4x - 10$ 102) _____
 A) -11 B) 9 C) 1 D) -19

Answer: D

Objective: (6.6) Evaluate Polynomial Function

ALVAREZLAB GFUNEV01...GFUNEV04

FUNCTE04 (6) INTERACTMATH SEC 6.6 EXE 47

ALVAREZ--VIDEO 83

Simplify the rational expression.

103) $\frac{(y+8)(y-5)}{(y-5)(y+9)}$ 103) _____
 A) $\frac{y+8}{y+9}$ B) $\frac{y-8}{y-9}$ C) $\frac{2y-5}{2y+4}$ D) $\frac{y+5}{y+4}$

Answer: A

Objective: (7.1) Simplify Rational Expression

ALVAREZLAB GFUNSL04, 08, 12

RATIONAL (1) INTERACTMATH SEC 7.1 EXE 13

ALVAREZ VIDEO 84

104) $\frac{3x-15}{x^2-25}$ 104) _____
 A) $-\frac{3}{x+5}$ B) $\frac{3}{x+5}$ C) $\frac{3}{x-5}$ D) $-\frac{12}{x-25}$

Answer: B

Objective: (7.1) Simplify Rational Expression

ALVAREZLAB GFUNSL04, 08, 12

RATIONAL (8) INTERACTMATH SEC 7.1 EXE 17

ALVAREZ--VIDEO 85

$$105) \frac{y^2 + 3y - 28}{y^2 + 16y + 63}$$

105) _____

A) $\frac{y - 4}{y + 9}$

B) $\frac{3y - 28}{16y + 63}$

C) $-\frac{y^2 + 3y - 28}{y^2 + 16y + 63}$

D) $\frac{3y + 28}{16y - 16}$

Answer: A

Objective: (7.1) Simplify Rational Expression

ALVAREZLAB GFUNSL04, 08, 12, 36, 40

RATIONAL (12) INTERACTMATH SEC 7.1 EXE 23

ALVAREZ--VIDEO 86

$$106) \frac{y^2 - 10y + 25}{25 - y^2}$$

106) _____

A) $\frac{y + 5}{-y + 5}$

B) $\frac{-y + 5}{y + 5}$

C) $y - 5$

D) $\frac{y - 5}{y + 5}$

Answer: B

Objective: (7.1) Simplify Rational Expression by Factoring Out -1

ALVAREZLAB GFUNSL04, 08, 12, 36, 40

RATIONAL (2,3,8,9) INTERACTMATH SEC 7.1 EXE 33

ALVAREZ VIDEO 87

Multiply the rational expressions and write the answer in lowest terms.

$$107) \frac{a^2 - 4b^2}{20ab^2} \cdot \frac{4a^2b}{a - 2b}$$

107) _____

A) $\frac{a^2 + 2ab}{5}$

B) $\frac{a^2 - 2ab}{5b}$

C) $\frac{a^2 + 2ab}{5b}$

D) $\frac{a + 2b}{5ab}$

Answer: C

Objective: (7.2) Multiply Rational Expressions

ALVAREZLAB GFUNSL15

RATIONAL (15,16,17) INTERACTMATH SEC 7.2 EXE 13

ALVAREZ VIDEO 88

Divide the rational expressions and write the answer in lowest terms.

$$108) \frac{m^2 - 16}{m^2 + 3m - 28} \div \frac{m^2 - 3m - 28}{m - 4}$$

108) _____

A) $\frac{m - 4}{(m + 7)(m - 7)}$

B) $\frac{m - 4}{m^2}$

C) $\frac{m + 4}{(m + 7)(m - 7)}$

D) $\frac{m - 4}{m - 7}$

Answer: A

Objective: (7.2) Divide Rational Expressions

ALVAREZLAB GFUNSL16,44

RATIONAL (18) INTERACTMATH SEC 7.2 EXE 17

ALVAREZ--VIDEO 89

Add or subtract the rational expressions with common denominators. Write the answer in lowest terms.

$$109) \frac{y^2 + 6y}{y + 5} + \frac{y^2 + 4y}{y + 5}$$

109) _____

A) $2y$

B) y

C) $2y^2$

D) $\frac{2y^2 + 6y}{y + 5}$

Answer: A

Objective: (7.3) Add or Subtract with Common Denominator

ALVAREZLAB GFUNSL13,14,17,18,21,22,71...78

RATIONAM (1,8,9) INTERACTMATH SEC 7.3 EXE 15

ALVAREZ--VIDEO 90

Perform the indicated operations and write the answer in lowest terms.

$$110) \frac{2}{x + 6} - \frac{5}{x - 6}$$

110) _____

A) $\frac{-3x + 42}{(x + 6)(x - 6)}$

B) $\frac{-3x - 42}{(x + 6)(x - 6)}$

C) $\frac{-3}{(x + 6)(x - 6)}$

D) $\frac{-3x + 18}{(x + 6)(x - 6)}$

Answer: B

Objective: (7.3) Add or Subtract with Unlike Denominators I

ALVAREZLAB GFUNSL71...78, 13,14,17,18,21,22,25,26,81...86

RATIONSU (1,2,3,7,8) INTERACTMATH SEC 7.3 EXE 39

ALVAREZ--VIDEO 91

Simplify the complex fraction.

$$111) \frac{\frac{4}{x} + \frac{7}{x^2}}{\frac{16}{x^2} - \frac{49}{x}}$$

111) _____

A) $\frac{4x^2 + 7}{16 - 49x}$

B) $\frac{1}{4 - 7x}$

C) $\frac{1}{4x - 7}$

D) $\frac{4x + 7}{16 - 49x}$

Answer: D

Objective: (7.4) Simplify Complex Fractions by Multiplying by LCD/LCD

ALVAREZLAB GFUNSL20,24,28,32,48,52,56,57,58,59,61...64

RATCOMEZ (6) RATCOME1 (1,2,7,8,9,10) INTERACTMATH SEC 7.4 EXE 45

ALVAREZ--VIDEO 92

$$112) \frac{\frac{2}{x} - \frac{5}{y}}{\frac{2}{x} + \frac{5}{y}}$$

112) _____

A) $\frac{x + y}{7(x - y)}$

B) $\frac{2y + 5x}{2y - 5x}$

C) $\frac{2y - 5x}{2y + 5x}$

D) $\frac{2x - 5y}{2x + 5y}$

Answer: C

Objective: (7.4) Simplify Complex Fractions by Multiplying by LCD/LCD

ALVAREZLAB GFUNSL20,24,28,32,52,56,57,58,59,61...64

RATCOMEZ (6) RATCOME1 (4,5,6) INTERACTMATH SEC 7.4 EXE 43

ALVAREZ--VIDEO 93

Find any excluded values and state the domain of the rational function using interval notation or set-builder notation as appropriate.

$$113) f(x) = \frac{9x - 2}{x^2 - 16}$$

113) _____

A) $D = \{x \mid x \neq 4 \text{ and } x \neq -4\}$

B) $D = \{x \mid x \neq 16\}$

C) $D = \left\{x \mid x \neq \frac{2}{9}\right\}$

D) $D = \{x \mid x \neq 4\}$

Answer: A

Objective: (7.5) State Domain of Rational Function

ALVAREZLAB GASYMD01...12

FUNCTDOD (7) INTERACTMATH SEC 7.5 EXE 13

ALVAREZ VIDEO 94

Solve the equation.

$$114) \frac{3}{y+3} - \frac{8}{y-3} = \frac{2}{y^2-9}$$

114) _____

A) {7}

B) {35}

C) $\{\sqrt{31}\}$

D) {-7}

Answer: D

Objective: (7.5) Solve Equation Involving Rational Expression

ALVAREZLAB GQLCDM01...04,11,12

QUADLCD (10) INTERACTMATH SEC 7.5 EXE 31

ALVAREZ--VIDEO 95

Solve the formula for the indicated variable.

$$115) W = \frac{P}{2} - L \quad \text{for } P$$

115) _____

A) $P = 2W + L$

B) $P = 2WL$

C) $P = 2W + 2L$

D) $P = 2W - 2L$

Answer: C

Objective: (7.5) Solve Formula for Indicated Variable

ALVAREZLAB GLITER11,12,...40

GEOLITE1 (4,5) LITERAL (1) LITERALE (1,16)

INTERACTMATH SEC 7.5 EXE 59

ALVAERZ VIDEO 96

Find the principal square root.

$$116) \sqrt{36}$$

116) _____

A) 6

B) 36

C) 7

D) 5

Answer: A

Objective: (8.1) Find Principal Square Root

ALVAREZLAB RADICALR (1) INTERACTMATH SEC 8.1 EXE 11

ALVAREZ VIDEO 97

Simplify using the product rule for radicals.

117) $\sqrt{63}$

A) $3\sqrt{7}$

B) $\sqrt{63}$

C) $9\sqrt{7}$

D) 21

117) _____

Answer: A

Objective: (8.1) Simplify Using Product Rule

ALVAREZLAB GRADSU02,03,31,32

RADICALR (2) INTERACTMATH SEC 8.1 EXE 27

ALVAREZ VIDEO 98

Perform the indicated operations. Write the answer in simplified radical form. Assume that all variables represent positive real numbers.

118) $12\sqrt{2} - 8\sqrt{2} - \sqrt{2}$

A) $4\sqrt{2}$

B) $5\sqrt{2}$

C) $3\sqrt{2}$

D) $-5\sqrt{2}$

118) _____

Answer: C

Objective: (8.1) Add/Subtract Square Roots

ALVAREZLAB **GRADSU09...10 21...24**

RADICALR (16) INTERACTMATH SEC 8.1 EXE 91

ALVAREZ VIDEO 99

Multiply. Write the answer in simplified radical form. Assume that all variables represent positive real numbers.

119) $\sqrt{7} \cdot \sqrt{35}$

A) $5\sqrt{7}$

B) 35

C) $\sqrt{12}$

D) $7\sqrt{5}$

119) _____

Answer: D

Objective: (8.2) Multiply Square Roots

ALVAREZLAB **GRADRU01...02**

RADICALM (1,2) INTERACTMATH SEC 8.2 EXE 7

ALVAREZ VIDEO 100