

Name _____

math0410 Exam #4 04041700aafm041024350m**www.alvarezmathhelp.com****MULTIPLE CHOICE. Choose the one alternative that best completes the statement or answers the question.****Solve the equation.**

1) $x + 3 = 7$ 1) _____
 A) 4 B) -4 C) -10 D) 10

Objective: (3.2) Use the Addition Property or the Multiplication Property to Solve Equations

2) $9x + 4x = 78$ 2) _____
 A) 6 B) -6 C) $\frac{78}{5}$ D) $-\frac{78}{5}$

Objective: (3.2) Use the Addition Property or the Multiplication Property to Solve Equations

3) $4(8x - 4) = 33x$ 3) _____
 A) -16 B) 16 C) -4 D) 4

Objective: (3.2) Use the Addition Property or the Multiplication Property to Solve Equations

4) $5x + 4 = 49$ 4) _____
 A) 9 B) 40 C) 44 D) 5

Objective: (3.2) Use Both Properties to Solve Equations

5) $9n - 4 = 59$ 5) _____
 A) 7 B) 54 C) 58 D) 10

Objective: (3.2) Use Both Properties to Solve Equations

6) $-14 = 8x - 6$ 6) _____
 A) -1 B) -16 C) -12 D) 4

Objective: (3.2) Use Both Properties to Solve Equations

7) $7(8x - 4) = 60x$ 7) _____
 A) -7 B) 7 C) -1 D) 1

Objective: (3.2) Use Both Properties to Solve Equations

8) $2(5x - 2) = 8x$ 8) _____
 A) 2 B) -2 C) -1 D) 1

Objective: (3.2) Use Both Properties to Solve Equations
m50-5

9) $5(y - 4) = 7y - 20$ 9) _____
 A) 0 B) -20 C) 20 D) -40

Objective: (3.2) Use Both Properties to Solve Equations

- 10) $1.1x + 4.3 = 0.7x + 1.14$ 10) _____
 A) -7.9 B) -7.8 C) 0.127 D) -7.11

Objective: (5.6) Solve Equations Containing Decimals
 m50-8

- 11) $\frac{5}{6}x + \frac{4}{3} = \frac{2}{3}x$ 11) _____
 A) -8 B) 8 C) -12 D) 12

Objective: (9.3) Solve Equations Containing Fractions or Decimals
 m50-15

- 12) $9x + 5 - 9x - 5 = 6x - 6x - 3$ 12) _____
 A) 0 B) -288
 C) all real numbers D) no solution

Objective: (9.3) Recognize Identities and Equations with No Solution
 m50-16

- 13) $2(x + 5) = (2x + 10)$ 13) _____
 A) 20 B) 0
 C) all real numbers D) no solution

Objective: (9.3) Recognize Identities and Equations with No Solution
 m50-17

Solve the equation for the indicated variable.

- 14) $A = P + PRT$ for T 14) _____
 A) $T = \frac{A - P}{PR}$ B) $T = \frac{P - A}{PR}$ C) $T = \frac{A}{R}$ D) $T = \frac{PR}{A - P}$

Objective: (9.5) Solve a Formula or Equation for One of Its Variables
 m50-18

Solve the inequality. Graph the solution set and write it in interval notation.

- 15) $21x + 9 > 3(6x + 4)$ 15) _____

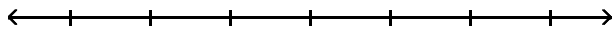

A) $(1, \infty)$

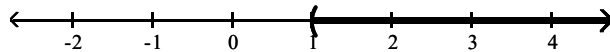

B) $(-\infty, 1)$

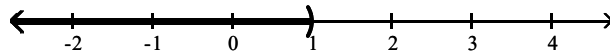

C) $(-\infty, 1]$

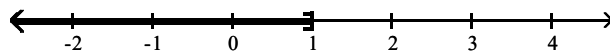

D) $[1, \infty)$

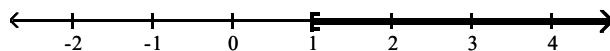

Objective: (9.6) Use Both Properties to Solve Inequalities
 m50-19

Determine whether the ordered pair is a solution of the given linear equation.

- 16) $-2y + 3x = -15$; $(5, 0)$ 16) _____
 A) no B) yes

Objective: (10.1) Determine whether an ordered pair is a solution of an equation in two variables.
 m50-20

Find three ordered pair solutions by completing the table. Then use the ordered pairs to graph the equation.

17) $y = 2x + 4$

17) _____

x	y
0	
1	
-1	

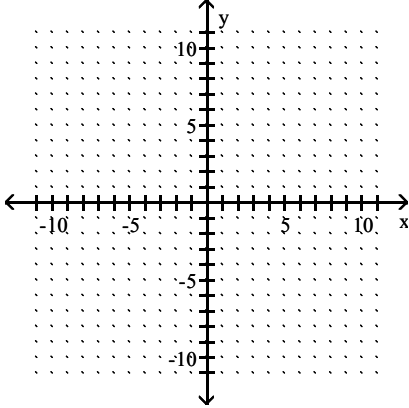

A)

x	y
0	4
1	6
-1	2

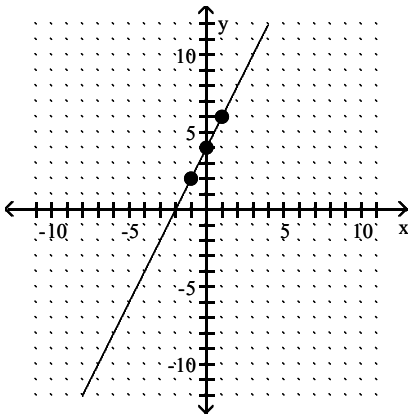

B)

x	y
0	0
1	4
-1	-4

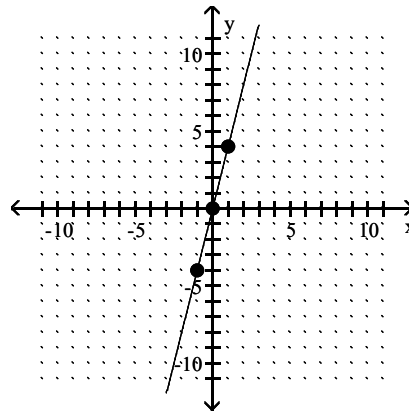

C)

x	y
0	4
1	2
-1	6

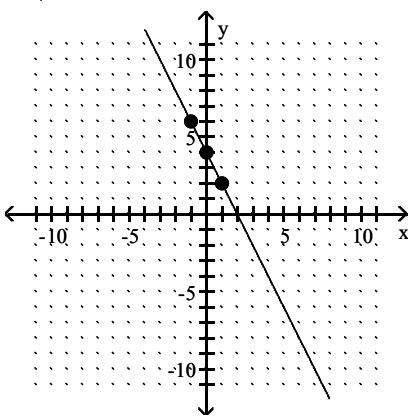

D)

x	y
0	-4
1	-2
-1	-6

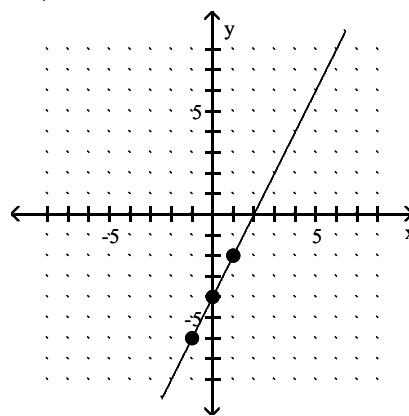

Objective: (10.2) Graph a linear equation by finding and plotting ordered pair solutions.

m50-21

Graph the linear equation.

18) $5y - 25x = 10$

18) _____

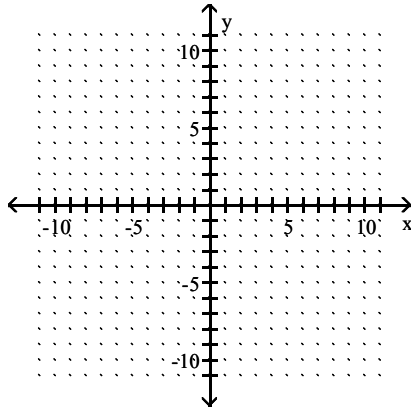

A)

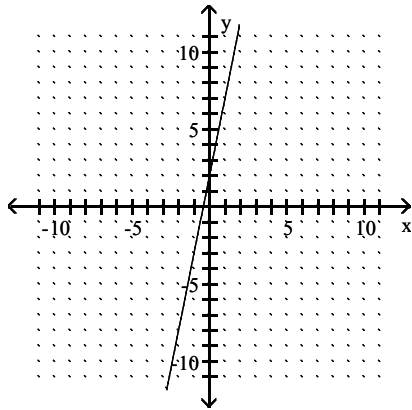

B)

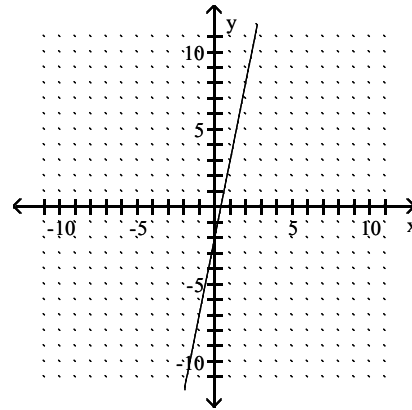

C)

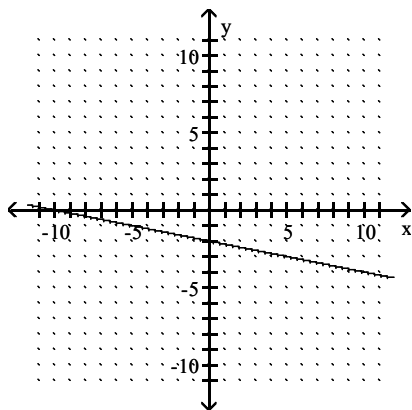

D)

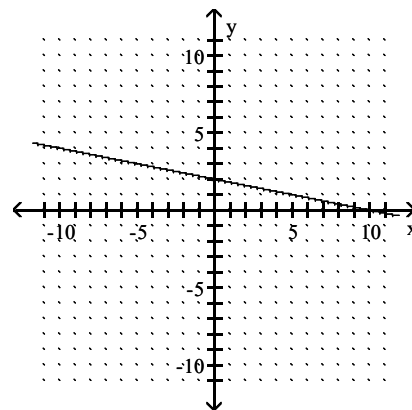

Objective: (10.2) Graph a linear equation by finding and plotting ordered pair solutions.

m50-22

Find the slope of the line that passes through the given points.

19) (8, 5) and (6, 9)

19) _____

A) -2

B) $-\frac{1}{2}$

C) 1

D) 2

Objective: (10.4) Find the slope of a line given two points of the line.

m50-23

Find an equation of the line described. Write the equation in slope-intercept form if possible.

- 20) Slope 2, through (5, 2) 20) _____
A) $y = 2x - 8$ B) $y = 2x + 8$ C) $x = 2y - 8$ D) $x = 2y + 8$

Objective: (10.5) Use the point-slope form to find an equation of a line given its slope and a point of the line.
m50-24

Evaluate the function.

- 21) Find $f(4)$ when $f(x) = x^2 + 4x - 3$. 21) _____
A) 29 B) 35 C) 3 D) -3

Objective: (10.6) Use function notation.
m50-25

Solve the system of equations by the addition method.

- 22) $\begin{cases} -2x + 3y = 2 \\ -3x + 5y = 2 \end{cases}$ 22) _____
A) (-4, -2) B) (-2, -4)
C) infinite number of solutions D) no solution

Objective: (11.3) Use the addition method to solve a system of linear equations.
m50-26

- 23) $\begin{cases} x + y = 7 \\ x + y = 4 \end{cases}$ 23) _____
A) no solution B) (0, 0) C) (7, 4) D) (0, 11)

Objective: (11.3) Use the addition method to solve a system of linear equations.
m50-27

- 24) $\begin{cases} -2x + 2y = -5 \\ 6x - 6y = 15 \end{cases}$ 24) _____
A) infinite number of solutions B) (0, 0)
C) (-2, 2) D) no solution

Objective: (11.3) Use the addition method to solve a system of linear equations.
m50-28

Multiply vertically.

- 25) $(6x - 1)(x^2 - 4x + 1)$ 25) _____
A) $6x^3 - 23x^2 + 2x - 1$ B) $6x^3 - 25x^2 + 10x - 1$
C) $6x^3 - 24x^2 + 6x + 1$ D) $6x^3 + 25x^2 - 10x + 1$

Objective: (12.3) Multiply polynomials vertically.
m50-33

Multiply.

- 26) $(3a - 7)^2$ 26) _____
A) $9a^2 - 42a + 49$ B) $9a^2 + 49$ C) $3a^2 - 42a + 49$ D) $3a^2 + 49$

Objective: (12.4) Square a binomial.
m50-34

- 27) $(x + 11)(x - 11)$ 27) _____
A) $x^2 - 121$ B) $x^2 - 22$ C) $x^2 - 22x - 121$ D) $x^2 + 22x - 121$

Objective: (12.4) Multiply the sum and difference of two terms.
m50-35

Simplify the expression. Write the result using positive exponents only.

28) $\frac{2^{-7}x^{-5}y^3}{2^{-4}x^{-8}y^6}$ 28) _____

A) $\frac{x^3}{8y^3}$

B) $\frac{1}{8x^8y^3}$

C) $\frac{3x^3}{y^3}$

D) $\frac{8}{x^3y^3}$

Objective: (12.5) Use all the rules and definitions for exponents to simplify exponential expressions.
m50-36

Find the quotient using long division.

29) $\frac{x^2 + 9x + 6}{x + 2}$ 29) _____

A) $x + 7 - \frac{8}{x + 2}$

B) $x + 7 + \frac{8}{x + 2}$

C) $\frac{x + 7}{x + 2}$

D) $x + 8$

Objective: (12.6) Use long division to divide a polynomial by another polynomial.
m50-38

Factor out the GCF from the polynomial.

30) $20x^4y + 36xy^3$ 30) _____

A) $4x(5x^3y + 9y^3)$

B) $4y(5x^4 + 9xy^2)$

C) $4xy(5x^3 + 9y^2)$

D) $xy(20x^3 + 36y^2)$

Objective: (13.1) Factor out the greatest common factor from a polynomial.
m50-39

Factor the four-term polynomial by grouping.

31) $3xy - 9x + 7y - 21$ 31) _____

A) $(3x + 7)(y - 3)$

B) $(3x - 3)(y + 7)$

C) $(3x + 7y)(y - 3)$

D) $(3x + y)(7y - 3)$

Objective: (13.1) Factor a polynomial by grouping.
m50-40

Factor the trinomial completely. If the polynomial cannot be factored, write "prime."

32) $x^2 - x - 42$ 32) _____

A) $(x + 7)(x - 6)$

B) prime

C) $(x + 6)(x - 7)$

D) $(x + 1)(x - 42)$

Objective: (13.2) Factor trinomials of the form $x^2 + bx + c$.
m50-41

Factor the binomial completely.

33) $z^2 - 121$ 33) _____

A) prime

B) $(z - 11)^2$

C) $(z + 11)(z - 11)$

D) $(z + 11)^2$

Objective: (13.5) Factor the difference of two squares.
m50-44

Answer Key

Testname: AAFM041024350MT4

- 1) A
- 2) A
- 3) A
- 4) A
- 5) A
- 6) A
- 7) A
- 8) A
- 9) A
- 10) A
- 11) A
- 12) D
- 13) C
- 14) A
- 15) A
- 16) A
- 17) A
- 18) A
- 19) A
- 20) A
- 21) A
- 22) A
- 23) A
- 24) A
- 25) B
- 26) A
- 27) A
- 28) A
- 29) A
- 30) C
- 31) A
- 32) C
- 33) C