

Name _____ **aafm1314018507590BB55555555t2**

website **www.alvarezmathhelp.com**

MULTIPLE CHOICE. Choose the one alternative that best completes the statement or answers the question.

Graph the function.

$$1) f(x) = \begin{cases} x + 4 & \text{if } x < 1 \\ -1 & \text{if } x \geq 1 \end{cases}$$

1) _____

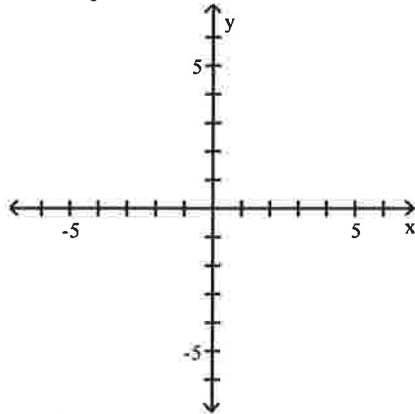

A)

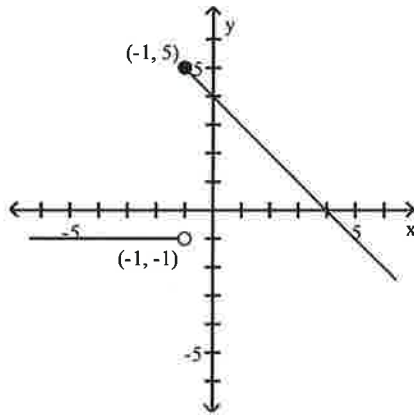

C)

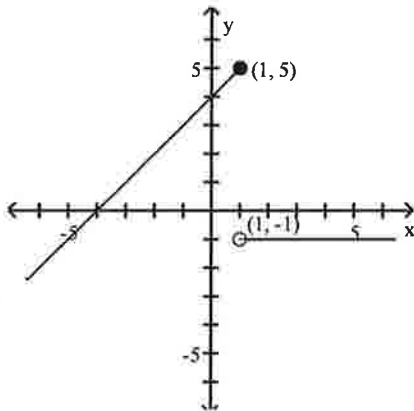

B)

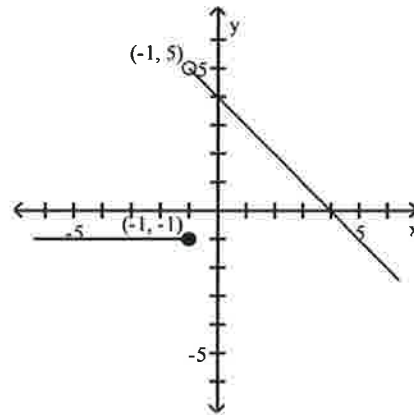

D)

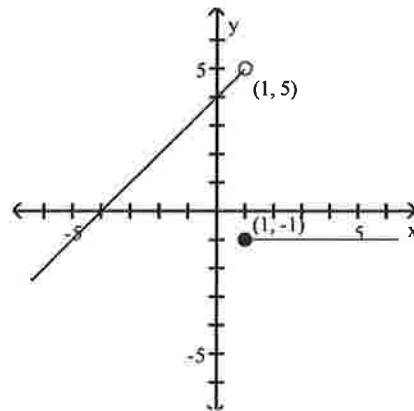

Objective: (2.2) Understand and Use Piecewise Functions

ALVAREZ--VIDEO 17 S55-16,17 S54-16,17 S79-14 S67-14
SULLIVAN147-63,64 M90-27 M75-25 M99-20,21,22
M57-12 m49-6 m50-10
M102 #24 m44 #5 m37-6 m51-8

Find and simplify the difference quotient $\frac{f(x+h) - f(x)}{h}$, $h \neq 0$ for the given function.

2) $f(x) = x^2 + 6x + 4$

A) $2x + h + 4$

B) $\frac{2x^2 + 2x + 2xh + h^2 + h + 8}{h}$

C) $2x + h + 6$

D) 1

2) _____

Objective: (2.2) Find and Simplify a Function's Difference Quotient

ALVAREZ--VIDEO 18 S55-9 S54-9 S79-9 S67-9
SULLIVAN147-55 M90-28 M75-26 M99-23 M57-13 m49-7
m50-11 M102 #25 m44 #6 m37-7 m51-9

Find the domain of the function.

3) $f(x) = \sqrt{19 - x}$

A) $(-\infty, 19) \cup (19, \infty)$

B) $(-\infty, \sqrt{19}]$

C) $(-\infty, 19]$

D) $(-\infty, \sqrt{19}) \cup (\sqrt{19}, \infty)$

3) _____

Objective: (2.6) Find the Domain of a Function

ALVAREZ--VIDEO 23 S55-6 S54-6 S79-6 S67-6 SULLIVAN147-52
M90-38 M75-28 M99-31,32 M57-14 m49-9 m50-12 m102 #30
m44 #7 m37-8 m51-11

Graph the equation.

4) $x^2 + y^2 - 6x - 12y + 29 = 0$

4) _____

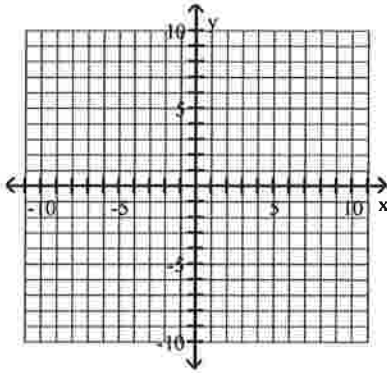

A)

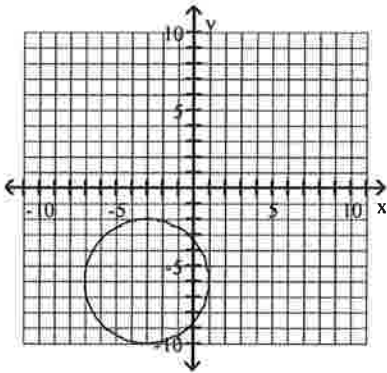

B)

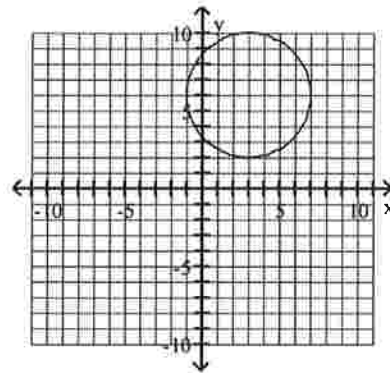

Objective: (2.8) Convert the General Form of a Circle's Equation to Standard Form

ALVAREZ--VIDEO 36 S55-5 S54-5 S79-3 S67-3
SULLIVAN147-48 M90-45 M75-35 M99-40,41 M57-19
m49-17 m50-17 M102 #41 M44 #12 m37-13 m51-16

Use the vertex and intercepts to sketch the graph of the quadratic function.

5) $f(x) = -x^2 - 8x - 7$

5) _____

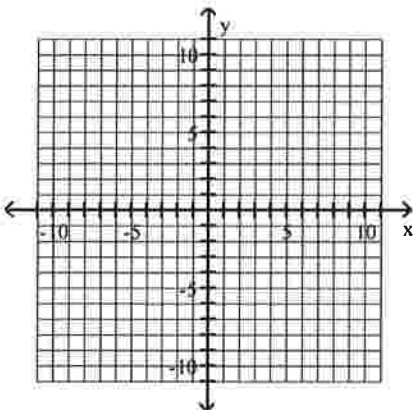

A)

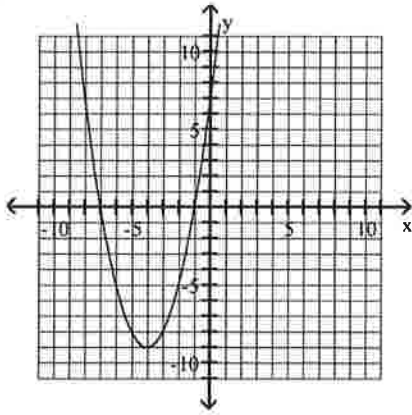

B)

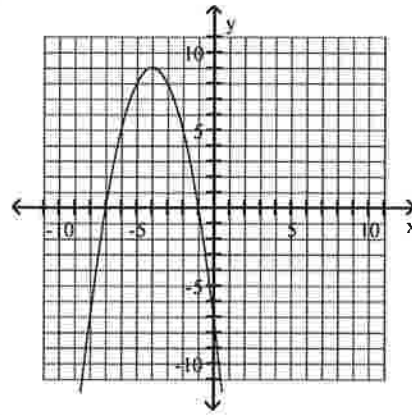

C)

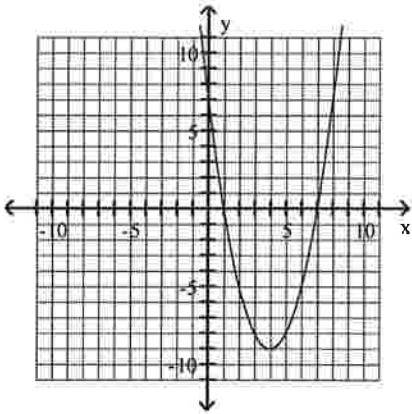

D)

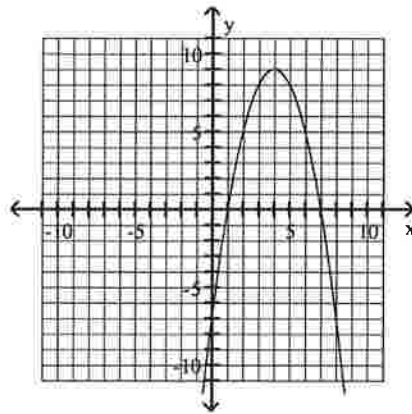

Objective: (3.1) Graph Parabolas

ALVAREZ--VIDEO 38 S55-23,24,25 S54-23,24,25 S79-24,25,26
 S67-24,25 SULLIVAN147- 81,82,83,85,86,87,88,89,90,91 M90-50
 M75-40 M99-30,42,43,44,45,46,47,54,55 M57-22-23 m49-19
 m50-20,21 m102 #43 m44 #13,14,15,16 m37-16 m51-21,22

Solve the problem.

- 6) An arrow is fired into the air with an initial velocity of 64 feet per second. The height in feet of the arrow t seconds after it was shot into the air is given by the function $h(x) = -16t^2 + 64t$. Find the maximum height of the arrow. 6) _____
- A) 192 ft B) 32 ft C) 64 ft D) 96 ft

Objective: (3.1) Solve Problems Involving a Quadratic Function's Minimum or Maximum Value

ALVAREZ--VIDEO 39 S55-26 S54-26 S79-28 S67-27 SULLIVAN147-94
 M90-51 M75-41 M99-43 M57-23 m49-20 m102#44,45,46 m37-16
 m51-17,18

Graph the polynomial function.

7) $f(x) = x^3 - 2x^2 - 5x + 6$

7) _____

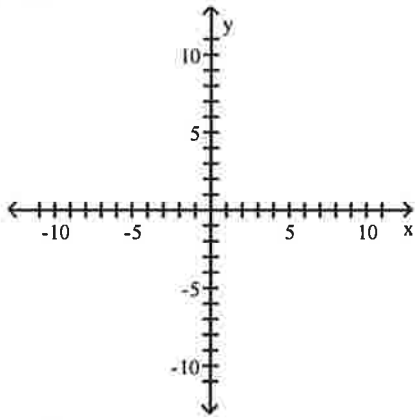

A)

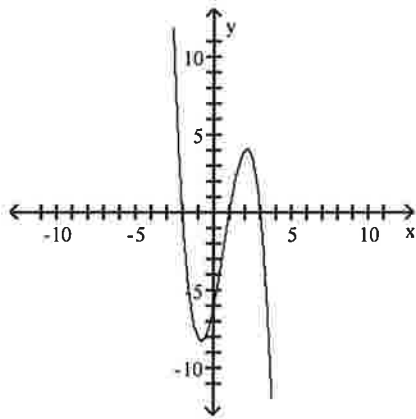

B)

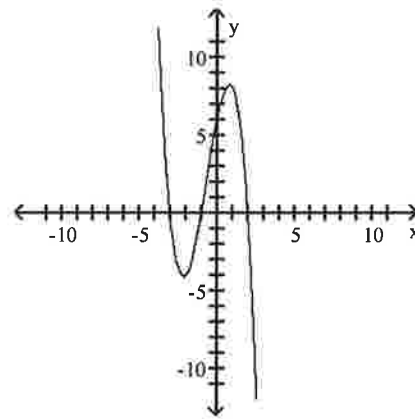

C)

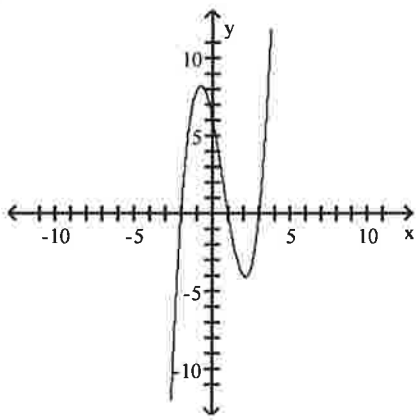

D)

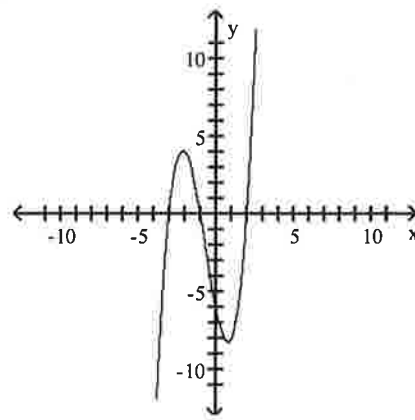

Objective: (3.2) Graph Polynomial Functions

**ALVAREZ--VIDEO 43 S55-27 S54-27 S79-29,30,31,32
 S67-24,25 SULLIVAN147-62 M90-26 M75-24
 M99-19 M57-28 m102 #50 m44 #18 m37-20 m51-7,25**

Use synthetic division to show that the number given to the right of the equation is a solution of the equation, then solve the polynomial equation.

8) $x^3 - 3x^2 - 10x + 24 = 0$; 2

A) {4, 3, 2}

B) {-4, 3, 2}

C) {-4, -3, 2}

D) {4, -3, 2}

8) _____

Objective: (3.3) Use the Factor Theorem to Solve a Polynomial Equation

ALVAREZ--VIDEO 45 S55-2 S54-2 S79-33 S67-28

SULLIVAN147-99,100,101 M90-53 M75-43

M99-48,49,50,51,53 M57-25 m49-23 m50-22 m102 #54 m44#17

m37-17 m51-23,24,25

Find a rational zero of the polynomial function and use it to find all the zeros of the function.

9) $f(x) = x^3 - 7x^2 + 19x - 13$

A) $\{-1, 3 + \sqrt{2}, 6 - \sqrt{2}\}$

B) $\{1, 2 + \sqrt{2}, 2 - \sqrt{2}\}$

C) $\{1, 3 + 2i, 3 - 2i\}$

D) $\{1, 2 + 3i, 2 - 3i\}$

9) _____

Objective: (3.4) Find Zeros of a Polynomial Function

ALVAREZ--VIDEO 47 S55-29 S54-29 S79-35 S67-29,30

SULLIVAN147-99,100,101 M90-55 M75-45 M99-52

M57-26 m49-24 m50-23 m102 #54 m44 #18 m37-19 m51-23,24,25

Find the vertical asymptotes, if any, of the graph of the rational function.

10) $\frac{x - 36}{x^2 - 11x + 24}$

A) $x = 8, x = 3$

B) $x = -8, x = -3$

C) $x = -36$

D) $x = 8, x = 3, x = -36$

10) _____

Objective: (3.5) Identify Vertical Asymptotes

ALVAREZ--VIDEO 54 S55-30 S54-30 S79-36 S67-31

SULLIVAN147-103,104 M90-57 M75-47 M99-58,59,60,61

m49-27 m50-26

m102 #56 m44 #21 m37-22 m51-27,28

Find the horizontal asymptote, if any, of the graph of the rational function.

11) $g(x) = \frac{5x^2 - 8x - 7}{9x^2 - 3x + 3}$

A) $y = \frac{8}{3}$

B) $y = 0$

C) $y = \frac{5}{9}$

D) no horizontal asymptote

11) _____

Objective: (3.5) Identify Horizontal Asymptotes

ALVAREZ--VIDEO 56 S55-30 S54-30 S79-36 S67-31

SULLIVAN147-103,104 M90-60 M75-50 M99-56,62,63,64,65

M57-33 m49-29 m50-28 m102 #57 m44 #23 m37-24 m51-29,30

Find the slant asymptote, if any, of the graph of the rational function.

$$12) f(x) = \frac{x^2 + 2x - 2}{x - 8}$$

12) _____

A) $y = x + 2$

B) $y = x$

C) $y = x + 10$

D) no slant asymptote

Objective: (3.5) Identify Slant Asymptotes

**ALVAREZ--VIDEO 57 M90-61 A ONLY M75-51 A ONLY
M99-57 M57-30 m49-30 m50-25
m102 #58 m44 #20 m37-21 m51-26**

Solve the problem.

- 13) The size of the beaver population at a national park increases at the rate of 5.1% per year. If the size of the current population is 180, find how many beavers there should be in 4 years. Use the function $f(x) = 180e^{0.051t}$ and round to the nearest whole number. 13) _____

A) 223

B) 221

C) 225

D) 219

Objective: (4.1) Evaluate Functions with Base e

**ALVAREZ--VIDEO 60 S55-35 S54-35 S79-43 S67-38 SULLIVAN147-117
M90-80 M75-68 M57-46 m50-29 m51-44**

- 14) The function $D(h) = 6e^{-0.4h}$ can be used to determine the milligrams D of a certain drug in a patient's bloodstream h hours after the drug has been given. How many milligrams (to two decimals) will be present after 8 hours? 14) _____

A) 0.24 mg

B) 0.73 mg

C) 4.19 mg

D) 147.20 mg

Objective: (4.1) Evaluate Functions with Base e

**ALVAREZ--VIDEO 62 S55-35 S54-35 S79-43 S67-38 SULLIVAN147-117
M90-80 M75-68 M99-87 M57-46 m50-29 m51-44**

Find the domain of the logarithmic function.

15) $f(x) = \ln(2 - x)$

15) _____

A) $(-\infty, 2)$

B) $(-2, \infty)$

C) $(-\infty, 0)$

D) $(-\infty, 2)$ or $(2, \infty)$

Objective: (4.2) Find the Domain of a Logarithmic Function

**ALVAREZ--VIDEO 63 S55-36 S54-36 S79-44,46,47,53
S67-39,41,47a SULLIVAN147-118 M90-64 M75-54
M99-66 M57-35 m49-31 m50-30
m44 #24 m37-25 m51-31**

Use properties of logarithms to expand the logarithmic expression as much as possible. Where possible, evaluate logarithmic expressions without using a calculator.

16) $\log_a \left(\frac{x^4 \sqrt[3]{x+5}}{(x-2)^2} \right)$ 16) _____

- A) $4 \log_a x + \frac{1}{3} \log_a (x+5) - 2 \log_a (x-2)$ B) $\log_a x^4 + \log_a (x+5)^{1/3} - \log_a (x-2)^2$
 C) $\log_a x^4 + \log_a (x+5)^{-3} - \log_a (x-2)^2$ D) $4 \log_a x - 3 \log_a (x+5) - 2 \log_a (x-2)$

Objective: (4.3) Expand Logarithmic Expressions

ALVAREZ--VIDEO 66 S55-40 S54-40 S79-59,60 S67-50,51
SULLIVAN147-123,124 M90-66 M75-56 M99-67,68,69,70
M57-36-37 m49-32 m50-31,32 m44 #25,26 m37-26,27 m51-32,33

Solve the equation by expressing each side as a power of the same base and then equating exponents.

17) $25^x + 7 = 125^x - 2$ 17) _____
 A) {16} B) {20} C) {13} D) {9}

Objective: (4.4) Use Like Bases to Solve Exponential Equations

ALVAREZ--VIDEO 70 S55-33 S54-33 S79-39 S67-34
SULLIVAN147-113 M90-67 M75-57 M99-73 M57-38
m49-33 m50-33 m44 #27 m37-28 m51-34

Solve the exponential equation. Use a calculator to obtain a decimal approximation, correct to two decimal places, for the solution.

18) $3^{x+6} = 8$ 18) _____
 A) -4.11 B) 6.53 C) 1.31 D) -0.35

Objective: (4.4) Use Logarithms to Solve Exponential Equations

ALVAREZ VIDEO 73 S55-44 S54-44 S79-52,66 S67-46,56
SULLIVAN147-130,131,132 M90-69 M75-59 M99-77 M57-39 M50-34
m37-29 m51-36

Solve the logarithmic equation. Be sure to reject any value that is not in the domain of the original logarithmic expressions. Give the exact answer.

19) $\log_4 (x+4) + \log_4 (x-2) = 2$ 19) _____
 A) {4, -6} B) {4} C) {5} D) {-6}

Objective: (4.4) Use the Definition of a Logarithm to Solve Logarithmic Equations

ALVAREZ--VIDEO 76 S55-42 S54-42 S79-62 S67-53
SULLIVAN147-127,129 M90-72 M75-62 M99-78 M57-40
m49-37 m50-35,36,37 m44 #30 m37-30 m51-38

20) $\log(4 + x) - \log(x - 4) = \log 3$

A) {8}

B) $\left\{\frac{3}{2}\right\}$

C) {-8}

D) \emptyset

20) _____

Objective: (4.4) Use the One-to-One Property of Logarithms to Solve Logarithmic Equations

ALVAREZ VIDEO79 S55-43 S54-43 S79-63,65 S67-54

SULLIVAN147-128 M90-73 M75-63 M99-80 M57-42 M50-37 m37-32 m51-40

21) $\ln x + \ln(x - 1) = \ln 12$

A) {4, -3}

B) {-3}

C) $\left\{\frac{13}{2}\right\}$

D) {4}

21) _____

Objective: (4.4) Use the One-to-One Property of Logarithms to Solve Logarithmic Equations

ALVAERZ--VIDEO 80 S55-42 S54-42 S79-64 S67-55

SULLIVAN147-127 M90-76 M75-65 M99-79,81 M57-43

m49-41 m50-38

m44 #32 m37-33 m51-41

Solve the problem.

22) Find out how long it takes a \$3100 investment to double if it is invested at 8% compounded semiannually. Round to the nearest tenth of a year. Use the formula $A = P\left(1 + \frac{r}{n}\right)^{nt}$.

A) 8.8 years

B) 9 years

C) 8.6 years

D) 9.2 years

22) _____

Objective: (4.4) Solve Applied Problems Involving Exponential and Logarithmic Equations

ALVAREZ VIDEO81 S55-46 S54-46 S79-70 S67-59 SULLIVAN35-29

M90-77 M75-66 M99-84 M57-44 M50-39 m37-34 m51-43

23) The function $A = A_0e^{-0.00693x}$ models the amount in pounds of a particular radioactive material stored in a concrete vault, where x is the number of years since the material was put into the vault. If 700 pounds of the material are placed in the vault, how much time will need to pass for only 375 pounds to remain?

A) 100 years

B) 180 years

C) 90 years

D) 95 years

23) _____

Objective: (4.4) Solve Applied Problems Involving Exponential and Logarithmic Equations

ALVAREZ--VIDEO 83 S55-47 S54-47 S79-71 S67-45

SULLIVAN147-136 M90-81 M75-69

M99-74,75,76,82,85,86,88 M57-48 m49-43 m50-40 m44 #34

m51-42,45

- 24) The population of a certain country is growing at a rate of 2.6% per year. How long will it take for this country's population to double? Use the formula $t = \frac{\ln 2}{k}$, which gives the time, t , for a population with growth rate k , to double. (Round to the nearest whole year.) 24) _____
- A) 27 years B) 26 years C) 28 years D) 29 years

Objective: (4.4) Solve Applied Problems Involving Exponential and Logarithmic Equations

ALVAREZ--VIDEO 84 S55-46 S54-46 S79-70 S67-59
SULLIVAN35-29 SULLIVAN147-136,140 M90-83 M75-70
M57-48 m49-44 m50-43 m44 #37 m51-46

Solve.

- 25) A fossilized leaf contains 9% of its normal amount of carbon 14. How old is the fossil (to the nearest year)? Use 5600 years as the half-life of carbon 14. 25) _____
- A) 36,378 B) 19,419 C) 761 D) 17,720

Objective: (4.5) Model Exponential Growth and Decay

ALVAREZ--VIDEO 87 S55-49 S54-49 S79-73,74 S67-62
SULLIVAN147-141,142 M90-81 ANOTHER METHOD M57-47 m51-45

Answer Key

Testname: AAFM1314SULL055T2SU

- 1) D
- 2) C
- 3) C
- 4) B
- 5) B
- 6) C
- 7) C
- 8) D
- 9) C
- 10) A
- 11) C
- 12) C
- 13) B
- 14) A
- 15) A
- 16) A
- 17) B
- 18) A
- 19) B
- 20) A
- 21) D
- 22) A
- 23) C
- 24) A
- 25) B